



JPT-W20Q

JPT-W25Q

## Electric Pallet Truck 2.0/2.5t

Long-tiller Design Makes Operations Easier and More Convenient;  
Small Turning Radius Requirements, Excellent Performances in Curved Aisles;  
Ideal Choice for Heavy Duty but Short Distance Applications.

**ZHEJIANG JOCKY MACHINERY  
TECHNOLOGY CO.,LTD**



## FEATURE



### Performance

- The innovative AC system offers strong power, accurate control and excellent performance
- High strength vertical gearbox provides reliable uptime
- Low-noise and durable hydraulic unit, high quality cylinder as well as hose ensure the high reliability of hydraulic system
- AMP connector and durable electric wires greatly reduce malfunctions of components.
- One-time formed fork, box type frame and adjustable linkage extends the life of undercarriage.



### Safety

- Curved design of front chassis avoids pinching point when lifting
- Curved design of bottom frame ensures proper ground clearance and avoids hurting operator's feet
- Emergency reverse belly button protects the operator from getting hurt.
- Emergency disconnecter will cut off power source to avoid accident when the truck goes out of control
- Anti-rolling back brake keeps the truck from skidding down when truck is out of control or travelling on ramp
- LBR option avoids cargo from falling down.
- Long operation tiller withstands most impacts from crashes.

### Operation

- With the new design of ergonomical tiller head, all buttons can be reached conveniently & comfortably
- Thanks to the long tiller design, it decreases the steering force greatly which leads to easy operations
- With its special fork design, it is suitable for all popular pallets.
- Over 180° handle rotation range tiller & compact size ensure small turning radius & excellent maneuverability
- Creep speed function: when tiller is in near vertical position, the driving speed will decrease automatically, allowing delicate operation in confined space.
- Creep Switch for vertical handle (optional)

### Maintenance

- AC traction motor, maintenance free
- Hour meter and battery indicator remind the operator of battery charging
- Easily remove the back cover by only losing two bolts; Access to all key components for inspection, maintenance and replacement.
- Easy access for battery maintenance.
- Vertical motor makes the inspection & service much more convenient.
- Control system allows easy trouble shooting
- Low voltage lift cut off design protects batteries.

# Electric Pallet Truck 2.0t

## JPT-W20Q

Distinguishing mark	1.1	Manufacturer			JUKILIFT	JUKILIFT
	1.2	Model designation			JPT-W20Q	JPT-W20Q
	1.3	Drive			Electric	Electric
	1.4	Operator type			Pedestrian	Pedestrian
	1.5	Load capacity	Q	kg	2000	2000
	1.6	Load center distance	c	mm	600	600
	1.8	Load distance , centre of drive axle to fork	x	mm	916 / 982	916 / 982
	1.9	Wheelbase	y	mm	1418	1418
	Service weight	2.1	Service weight		kg	530
2.2		Axle loading, laden front/rear		kg	950 / 1580	820 / 1580
2.3		Axle loading, unladen front/rear		kg	425 / 105	295 / 105
Tyres/chassis	3.1	Tyre type			Polyurethane	Polyurethane
	3.2.1	Tyre size, front		mm	Φ85x70	Φ85x70
	3.3.1	Tyre size, rear		mm	Φ230x75	Φ230x75
	3.4	Additional wheels (castor wheels)		mm	Φ85x48	Φ85x48
	3.5	Wheels, number front/rear (x=drive wheels)		mm	1 x +2 / 4	1 x +2 / 4
	3.6.1	Tread width, front	b10	mm	498	498
	3.7.1	Tread width, rear	b11	mm	515	515
Dimensions	4.4	Lift height	h3	mm	120	120
	4.9	Height of tiller handle in drive position min./max.	h14	mm	715 / 1200	715 / 1200
	4.15	Lowered height	h13	mm	85	85
	4.19	Overall length	l1	mm	1748	1748
	4.20	Length to face of forks	l2	mm	621	621
	4.21	Overall width	b1/b2	mm	710	710
	4.22	Fork dimensions	s/e/l	mm	55 x 170 x 1150	55 x 170 x 1150
	4.25	Distance between fork-arms	b5	mm	685	685
	4.32	Ground clearance, center of wheelbase	m2	mm	30	30
	4.34.1	Aisle width for pallets 1000×1200 crossways	Ast	mm	2400	2400
	4.34.2	Aisle width for pallets 800×1200 crossways	Ast	mm	2255	2255
	4.35	Turning radius	Wa	mm	1600	1600
Performance data	5.1	Travel speed, laden/unladen		km/ h	5 / 5.5	5 / 5.5
	5.2	Lifting speed, laden/unladen		m/s	0.051 / 0.060	0.051 / 0.060
	5.3	Lowering speed, laden/unladen		m/s	0.032 / 0.039	0.032 / 0.039
	5.8	Max. gradeability, laden/unladen		%	8 / 16	8 / 16
	5.10	Service brake			Electromagnetic	Electromagnetic
Electric-engine	6.1	Drive motor rating S2 60 min		kW	1.1	1.1
	6.2	Lift motor rating at S3 15%		kW	0.84	0.84
	6.4	Battery voltage/nominal capacity		V/Ah	24 / 210	24 / 205
	6.5	Battery weight		kg	190	62
	Addition data	8.1	Type of drive control			AC
10.5		Steering design			Mechanical	Mechanical
10.7		Sound pressure level at the driver's ear		dB(A)	74	74

If there are improvements of technical parameters or configurations, no further notice will be given. The diagram shown may contain non-standard configurations.

# Electric Pallet Truck 2.5t

## JPT-W25Q

Distinguishing mark	1.1	Manufacturer			JUKILIFT	JUKILIFT
	1.2	Model designation			JPT-W25Q	JPT-W25Q
	1.3	Drive			Electric	Electric
	1.4	Operator type			Pedestrian	Pedestrian
	1.5	Load capacity	Q	kg	2500	2500
	1.6	Load center distance	c	mm	600	600
	1.8	Load distance , centre of drive axle to fork	x	mm	916 / 982	916 / 982
	1.9	Wheelbase	y	mm	1418	1418
	Service weight	2.1	Service weight		kg	565
2.2		Axle loading, laden front/rear		kg	985 / 1580	820 / 1580
2.3		Axle loading, unladen front/rear		kg	460 / 105	295 / 105
Tyres/chassis	3.1	Tyre type			Polyurethane	Polyurethane
	3.2.1	Tyre size, front		mm	Φ85x70	Φ85x70
	3.3.1	Tyre size, rear		mm	Φ230x75	Φ230x75
	3.4	Additional wheels (castor wheels)		mm	Φ85x48	Φ85x48
	3.5	Wheels, number front/rear (x=drive wheels)		mm	1 x +2 / 4	1 x +2 / 4
	3.6.1	Tread width, front	b10	mm	498	498
	3.7.1	Tread width, rear	b11	mm	515	515
Dimensions	4.4	Lift height	h3	mm	120	120
	4.9	Height of tiller handle in drive position min./max.	h14	mm	715 / 1200	715 / 1200
	4.15	Lowered height	h13	mm	85	85
	4.19	Overall length	l1	mm	1748	1748
	4.20	Length to face of forks	l2	mm	621	621
	4.21	Overall width	b1/b2	mm	710	710
	4.22	Fork dimensions	s/e/l	mm	55 x 170 x 1150	55 x 170 x 1150
	4.25	Distance between fork-arms	b5	mm	685	685
	4.32	Ground clearance, center of wheelbase	m2	mm	30	30
	4.34.1	Aisle width for pallets 1000×1200 crossways	Ast	mm	2400	2400
	4.34.2	Aisle width for pallets 800×1200 crossways	Ast	mm	2255	2255
4.35	Turning radius	Wa	mm	1600	1600	
Performance data	5.1	Travel speed, laden/unladen		km/ h	5 / 5.5	5 / 5.5
	5.2	Lifting speed, laden/unladen		m/s	0.051 / 0.060	0.051 / 0.060
	5.3	Lowering speed, laden/unladen		m/s	0.032 / 0.039	0.032 / 0.039
	5.8	Max. gradeability, laden/unladen		%	8 / 16	8 / 16
	5.10	Service brake			Electromagnetic	Electromagnetic
Electric-engine	6.1	Drive motor rating S2 60 min		kW	1.1	1.1
	6.2	Lift motor rating at S3 15%		kW	0.84	0.84
	6.4	Battery voltage/nominal capacity		V/Ah	24 / 240	24 / 205
	6.5	Battery weight		kg	220	62
Addition data	8.1	Type of drive control			AC	AC
	10.5	Steering design			Mechanical	Mechanical
	10.7	Sound pressure level at the driver's ear		dB(A)	74	74

If there are improvements of technical parameters or configurations, no further notice will be given.  
The diagram shown may contain non-standard configurations.

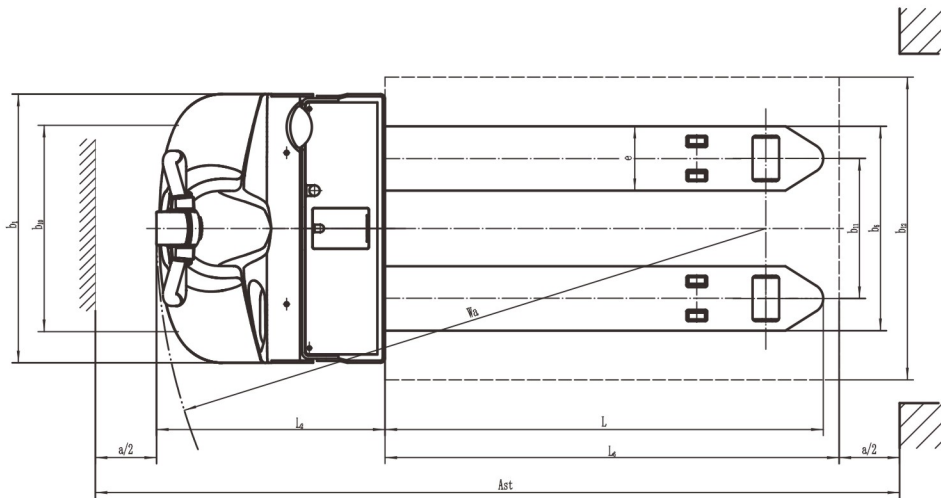
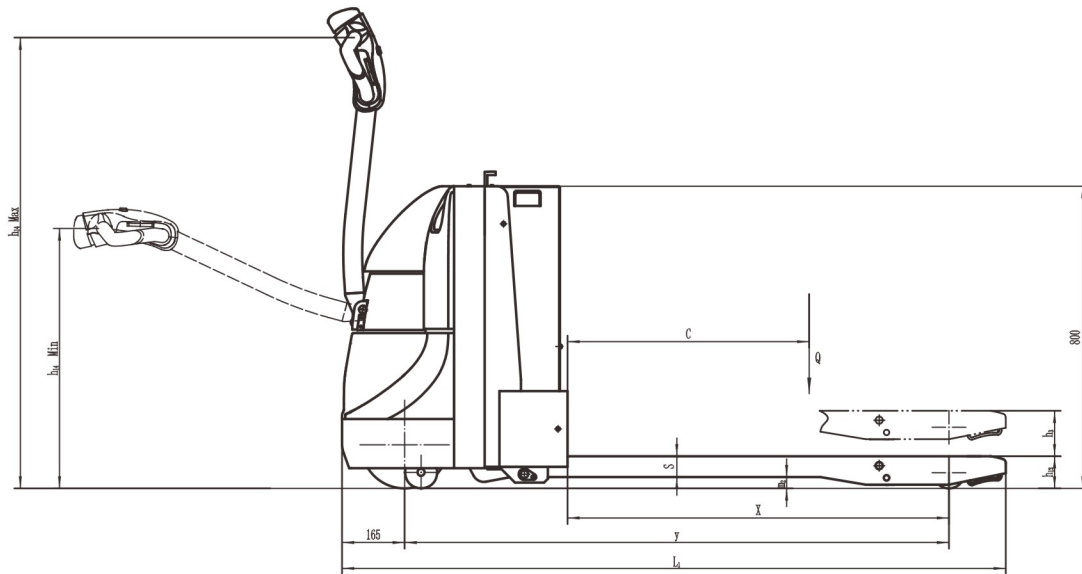

## Load Capability Chart

Fork length ( mm )	Load capacity ( kg )
	JPT-W20Q
850	
1000	
1150	
1220	2000KG
1300	
1450	
1600	
1800	1800KG
2000	
2200	
2400	1600KG

## Option

No.	Optional items	JPT-W20Q/JPT-W25Q
1.1	Fork dimension	●685*1150○685* ( 850, 1000, 1220, 1300, 1450, 1600, 1800, 2000, 2200, 2400 ) ○540* ( 850, 1000, 1150, 1220, 1300, 1450, 1600, 1800, 2000, 2200, 2400 )
1.3	Fork lowered height	●85
1.4	Fork carriage width	○726
1.5	backrest height	○1220mm ( 48in ) ○1520mm ( 60in )
2.1	Load wheel type	●Double○Single (only for fork length<1800)
2.2	Load wheel material	●PU
2.3	Drive wheel material	●PU○Patterned PU○Rubber
2.7	Battery capacity	●205Ah ( Li-ion ) ○210Ah ( Lead-acid ) ○230Ah ( Lead-acid ) ○240Ah ( Lead-acid )
2.8	Charger	●24V-50A External Li-ion○24V-100A External Li-ion○24V-30A External Lead-acid
2.9	Battery indicator	●With time (Bluetooth)
3.3	Castor wheels	●Yes and not customized○No
3.4	Water auto-filling system	●No○Yes and not customized (only for Lead-acid battery)
3.16	Vertical handler working	●Yes and not customized
3.21	Electronic sale	●No ○Yes and not customized (only for 1150*715 Double wheels and 1150*570 Double wheels)
3.22	Electronic sale with print	●No○Yes and not customized
3.23	Telematics	●No○Yes and not customized (only for Li-ion battery)
4.1	Battery side pull function	●No○Yes and not customized(bracket unavailable)
4.2	Cold storage	●No○Yes and not customized
5.1	Battery side pull attachment	●No○Yes and not customized
5.3	Password lock	●No○Yes and not customized
5.6	Side pull trolley	●No○Yes and not customized

Note : ●Standard ○ Optional - Inconformity