

本目录所述之产品，因更新和改良，可能不经事先预告，而对产品外观，规格及内容进行修改，特此声明敬请见谅！

The specification and/or appearance of the equipment described in this catalogue are subject to change without previous notice because of modification.



JOCKY®

Joyful stitching with me makes you lucky



ZHEJIANG JOCKY MACHINERY TECHNOLOGY CO., LTD.
浙江劲悦机械科技有限公司

Add: Rm.1009,Tongfang Fortune Bldg. No.334 Fengqi Rd, Hangzhou, 310003, China.
Cell/Wechat/WhatsApp ID: 0086 13357127700
E-mail: sales@jockytech.com

PROFESSIONAL SEWING MACHINERY SUPPLIER

2025

图标说明 一览表

Symbols Table

 型号 Model	 机针 Needle	 机针数 No. of Needle	 线数 No. of Threads	 针迹长度 Stitch length mm
 倒回缝 Back reverse	 自动剪线 Auto trimmer	 自动抬压脚 Auto foot lifter AUTO	 切刀尺寸 Cutter size mm	 针间距 Needles gauge
 薄料 Light materials	 中厚料 Medium materials	 厚料 Heavy materials	 压脚提升高度 Presser lift height (mm)	 缝纫速度 Sewing Speed S.p.m.
 功能应用 Application	 下送料 Bottom feed	 针送料 Needle feed	 上下送料 Top and bottom feed	 综合送料 Comprehensive feed
 卧式标准旋梭 Horizontal Hook (standard)	 卧式大旋梭 Horizontal Hook (large)	 立式标准旋梭 Vertical Hook (standard)	 立式大旋梭 Vertical Hook (large)	 摆梭 Shuttle hook
 弯针 Looper	 线迹宽度 Stitch Width mm	 线迹长度 Stitch Length mm	 差动比 Differential ratio	 拔线器 Thread wiper
 锁眼尺寸(平) Button holing size (horizontal)	 锁眼尺寸(圆) Button holing size (round)	 钉扣样式 Button type	 纽扣直径 Button diameter	 扣眼尺寸 Button hole size
 套结长度 Bar tack length mm	 套结宽度 Bar tack width mm	 缝制范围 Sewing area	 线迹数量 Stitch number	 针杆行程 Needle Bar Stroke mm
 曲折摆幅 Zigzag stitch mm	 缝制厚度 Sewing thickness mm	 操作空间 Working space	 立柱高度 Post bed height	 立柱宽度 Post bed width
 电机功率 Power w	 包装箱尺寸 Packing size mm	 净重/毛重 Weight NW/GW Kg		

产品目录

Product Contents



AUTOMATIC MACHINE SERIES	01
LOCKSTITCH SEWING MACHINE SERIES	17
OVERLOCK SEWING MACHINE SERIES	27
INTERLOCK SEWING MACHINE SERIES	35
MULTI-NEEDLE SEWING MACHINE SERIES	37
BUTTON ATTACHING MACHINE SERIES	39
BUTTON HOLING MACHINE SERIES	43
BAR TACKING MACHINE SERIES	45
PATTERN MACHINE SERIES	47
ZIGZAG SEWING MACHINE SERIES	51
SPECIAL SEWING MACHINE SERIES	55
BAG CLOSER MACHINE SERIES	75
EMBROIDERY MACHINE SERIES	77
QUILTING MACHINE SERIES	79
CUTTING MACHINE SERIES	83
FINISHING & PRE-SEWING EQUIPMENT SERIES	91



JOCKY®

Joyful stitching with me makes you lucky

30 +

YEARS INDUSTRY EXPERIENCE

100 +

EXPORTING COUNTRIES

15 +

EXCLUSIVE AGENTS

1000 +

COOPERATIVE FACTORIES



公司简介

Company Introduction

浙江劲悦机械科技有限公司是觅林集团旗下专业从事服装设备功能开发和智能应用研究的企业。拥有稳定的生产基地,合作生产各类缝制机械设备。我们是缝制机械的成套设备供应商。

公司品牌“JOCKY”寓意“尽享速度和力量”。自2005年以来,公司将“打造低碳、高效、人机友好型生产环境”作为自己的使命,致力于智能化和自动化技术研发和应用,不断优化设备解决方案,工厂业主的生产效率普遍提升,生产工人的愉悦感和幸福感不断增强。

JOCKY牌缝制机械的应用涉及衣、食、住、行、玩(娱)各个领域。JOCKY牌缝制机械产品涵盖缝前(裁切)、缝中(缝纫和绣花)和缝后(熨烫印花等)全系列设备,广泛应用于服装、鞋帽、汽车内饰、皮革制品,家用纺织品,运动用品以及玩具等。

我们真诚欢迎广大客商长期合作,代理JOCKY品牌或者个性化定制,共创美好事业。

Zhejiang jocky Machinery Technology Co.Ltd. is a subsidiary of Meetlin Group, specialized in the development of garment equipment and research of intelligent application. It has a stable production base which can produce all kinds of sewing machines and related equipment. We are professional supplier of complete equipment in sewing machinery.

The brand JOCKY means-Enjoy Speed And Power. Our mission is to build a low carbon, high efficiency, human-machine friendly working environment since 2005. We are committed to the development and application of intelligence and automation technology. To make production efficiency generally improved and the workers' sense of pleasure and happiness constantly enhanced during working, we continue to optimize equipment solutions.

The application of JOCKY brand sewing machines involves food, clothing, shelter, transportation, entertainment multi-field. JOCKY brand sewing machinery products cover a full range of equipment including pre-sewing equipment(cutting), sewing equipment(sewing and embroidery) and finishing equipment (ironing, printing etc), which are widely used in clothing, shoes and hats, automotive interiors, leather products, home textiles, sporting goods and toys etc.

We sincerely hope to establish long-term cooperation with customers, being agent of JOCKY machinery, or personalized customization for a splendid future!





企业文化 / Company Culture

Our Mission 我们的使命

Pursue a human-machine friendly production environment.

追求人机友好的生产环境。

Our Vision 我们的愿景

Joyful stitching with me makes you lucky.

享受速度和力量带给我们的美好体验。

Our Values 我们的价值观

Expand business with integrity and build the future with gratitude.

凭诚信拓商路，以感恩筑未来。



羽绒服/For Down Jacket

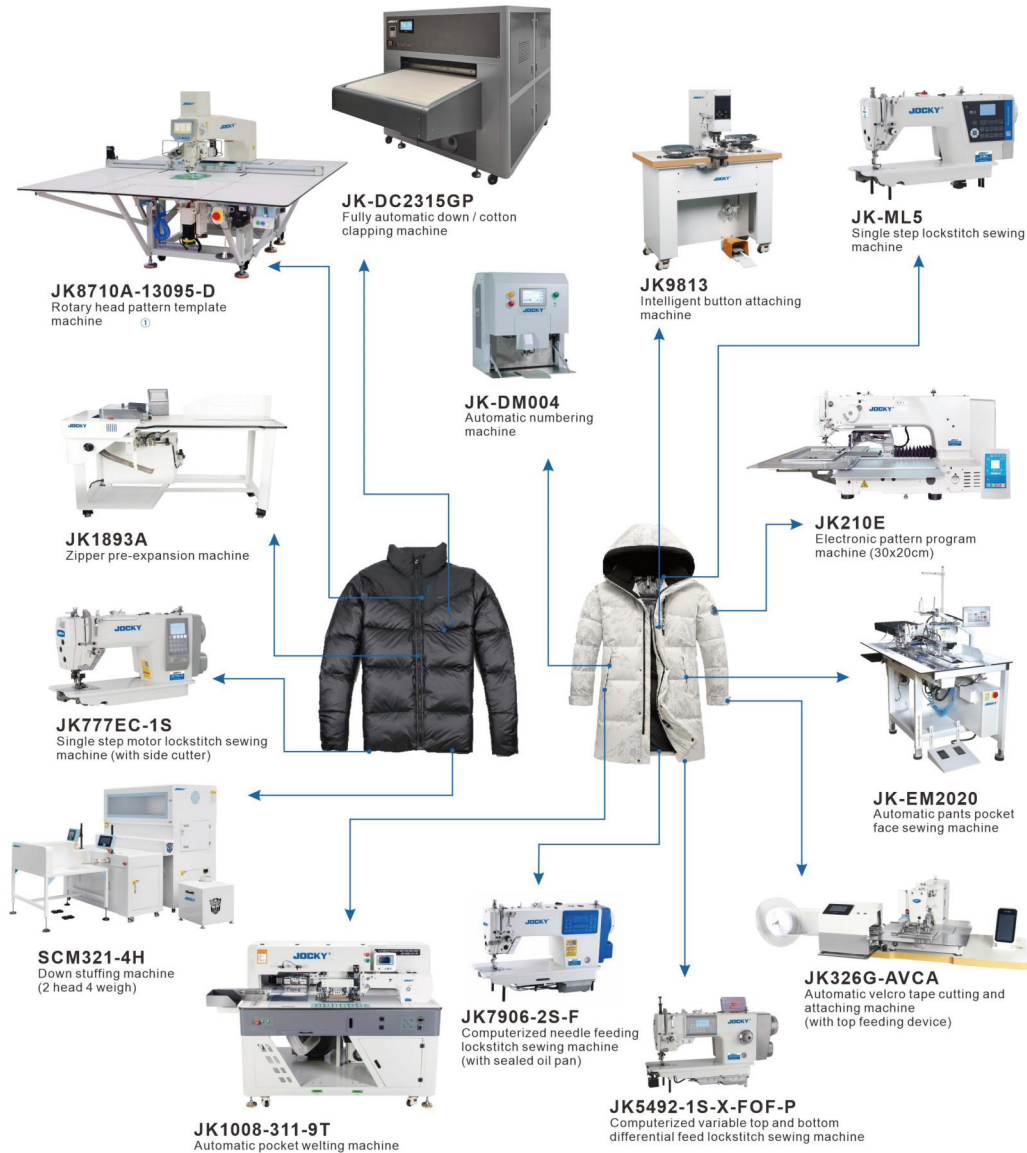

牛仔/For Jeans

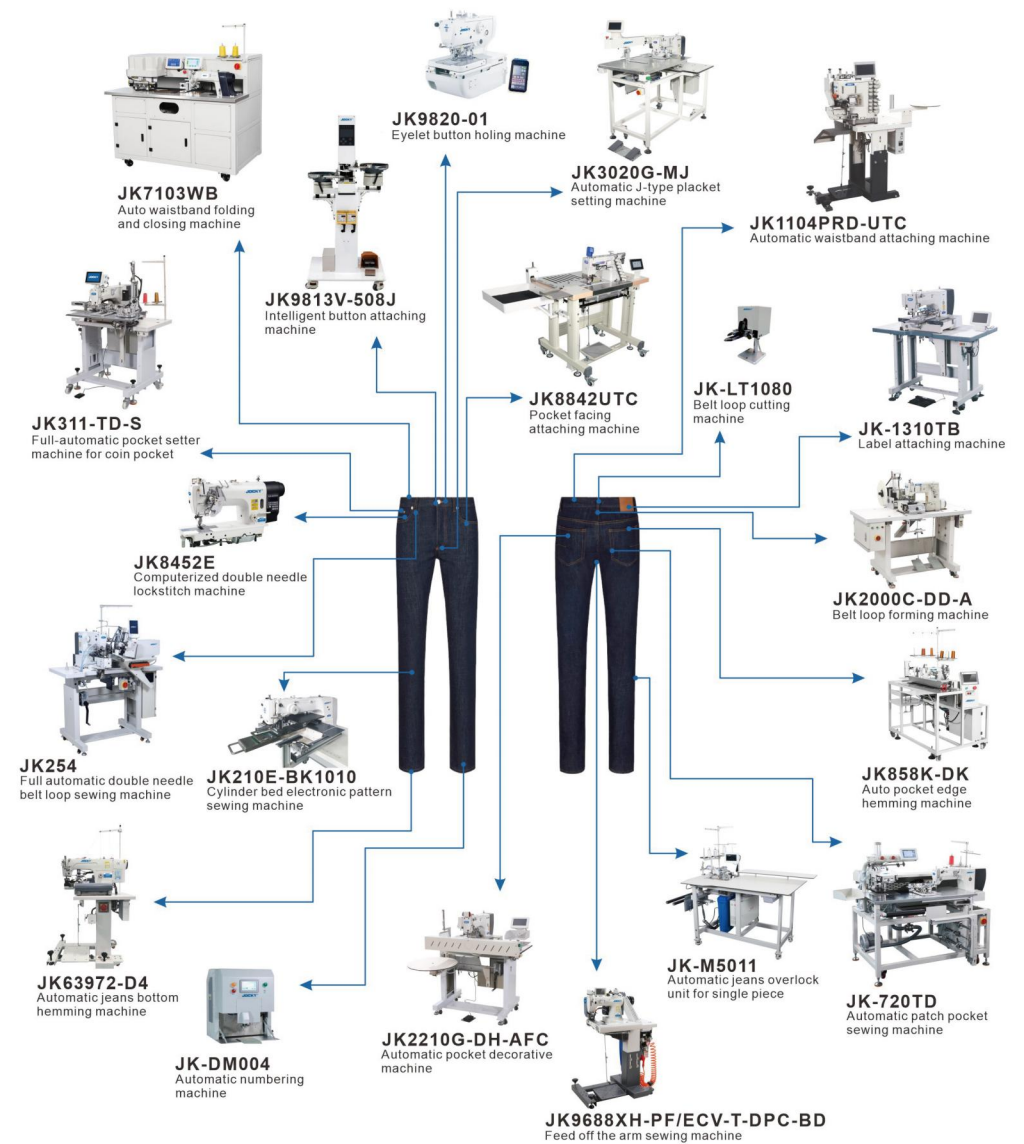

T恤 POLO衫/For T-shirt & POLO Shirt



帽子/For Hat

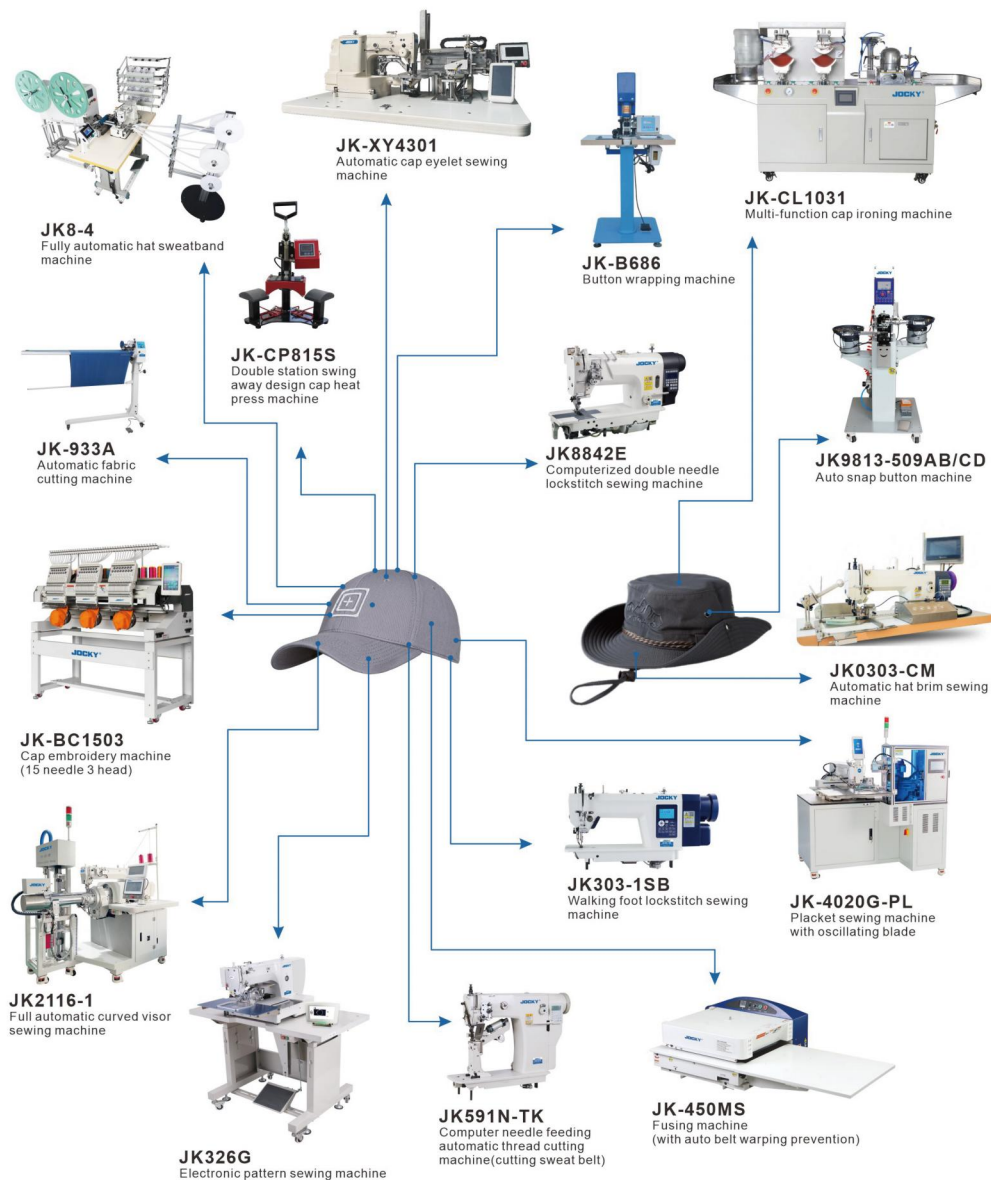

运动鞋/For Sports Shoes

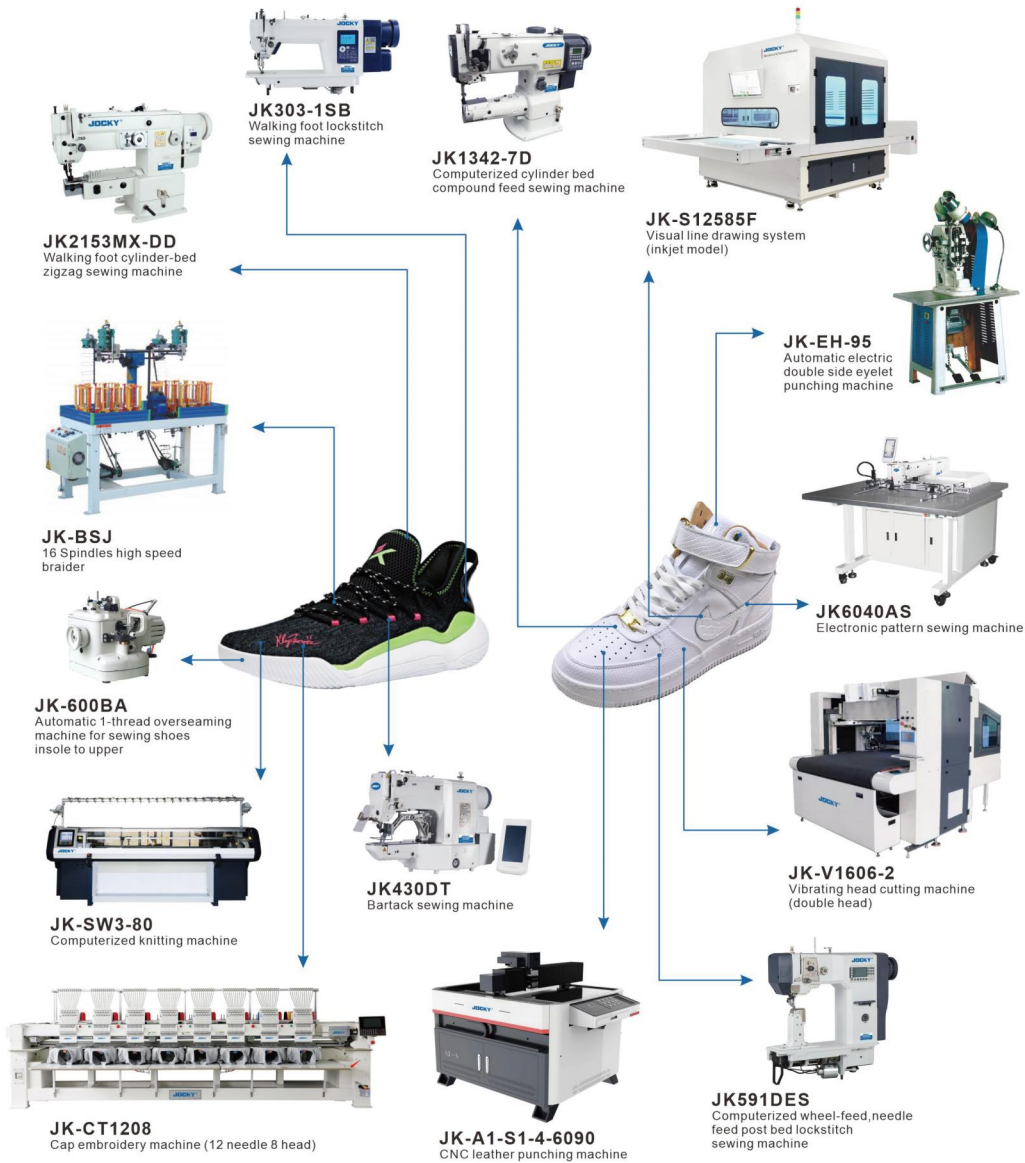

背包/For Backpack

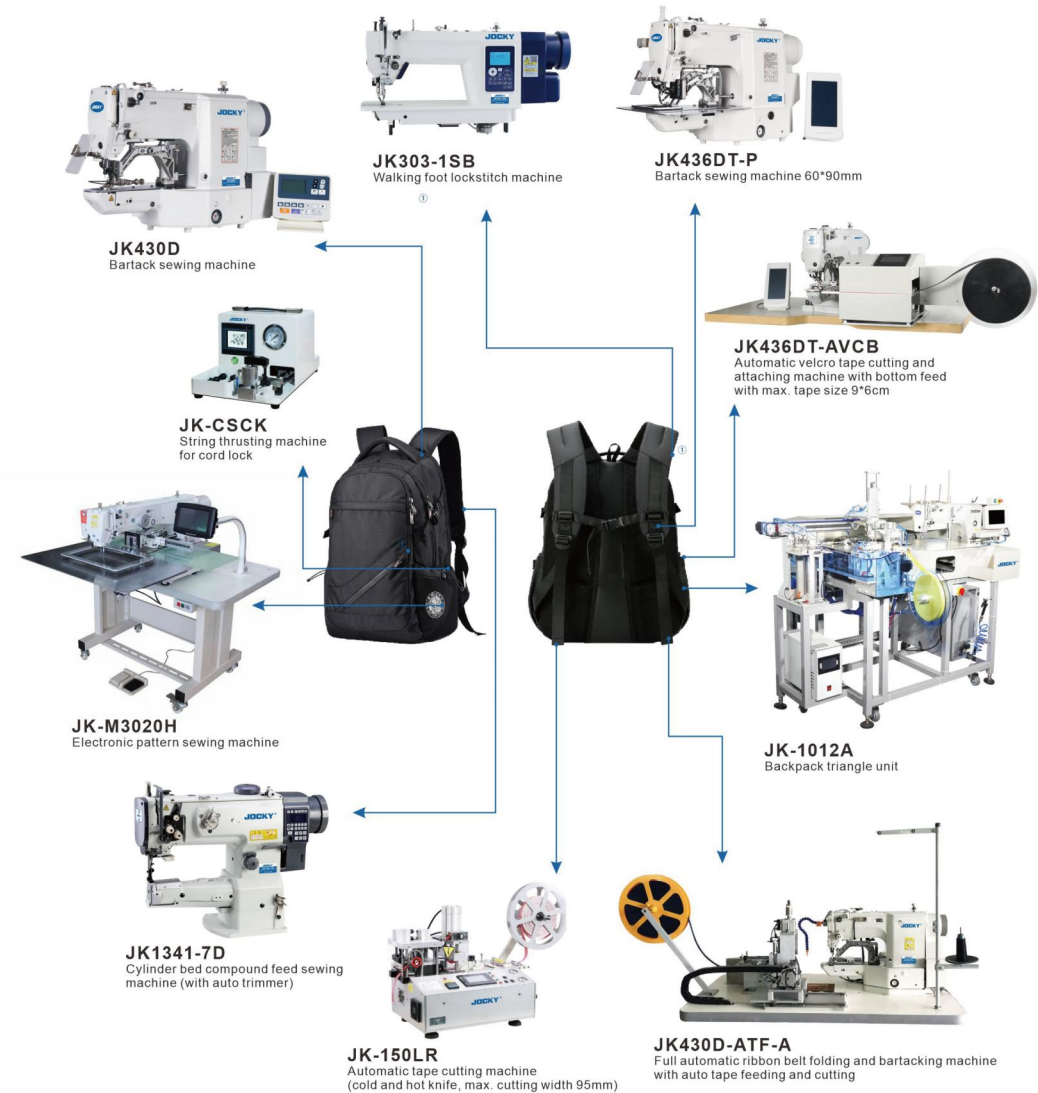

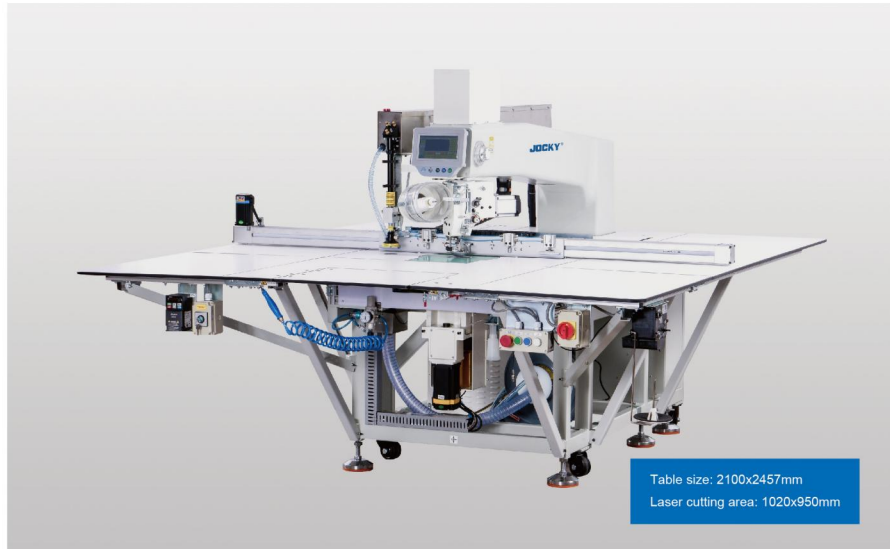

JK8710A-13095-J 全自动模板机

Automatic pattern template sewing machine (1300x950mm, with rotatable head and laser cutter)

Advantages of template machine:

- No need for skilled worker, save labor costs;
- Increase efficiency by at least 10%;
- Standardized production, unified and beautiful finished product;
- With various functions, it can replace machines such as pattern machines and pocket welting sewing machines;
- Only the template is moved during the sewing process, and the pieces aren't moved, which can ensure that the pieces don't deform to the greatest extent.



	DBx1 10#(7-14#)	0.5-12.7	20	4	750W 220V	3000	2050x1380x1875	677/788
JK8710A-13095	DBx1 10#(7-14#)	0.5-12.7	20	4	850W 220V	3000	2050x1380x1875	739/850



JK8310A-13085 全自动模板机

Automatic pattern template sewing machine (1300x850mm)

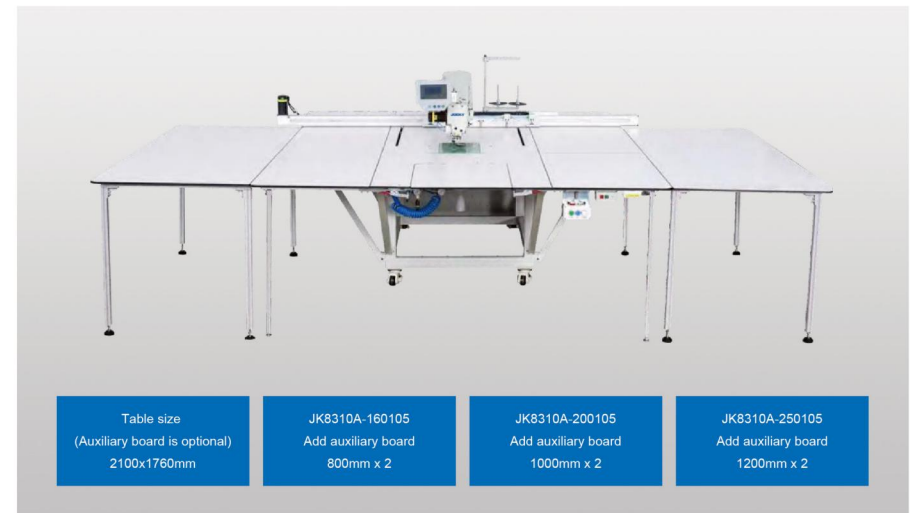

JK8310A-160105 全自动模板机

Automatic pattern template sewing machine (1600x1050mm)

	DBx1 8#(7-14#)	0.5-12.7	20	4	750W 220V	3000	1870x1335x1525	505/620
JK8310A-13085	DBx1 8#(7-14#)	0.5-12.7	20	4	750W 220V	3000	1990x1247x1530	634/749



JK8110A-8045 全自动模板机
Automatic pattern template sewing machine (800x450mm)



JK8510A-3830-XF 全自动模板机
Automatic pattern template sewing machine (380x300mm)



JK8820A-12080H-SJ 全自动模板机
Automatic pattern template sewing machine (1200x800mm)



JK8400A-6055H 全自动模板机
Automatic pattern template sewing machine (600x550mm)

Applicable types of template machine:

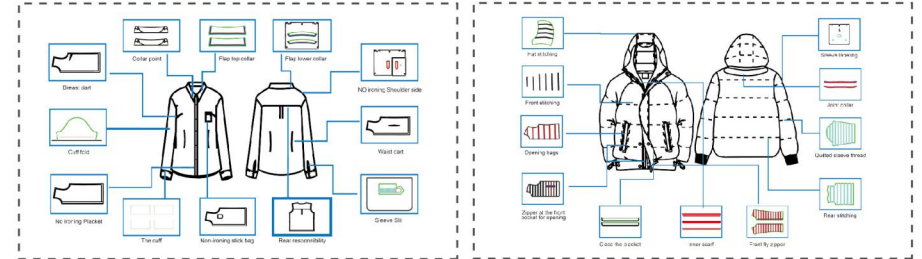
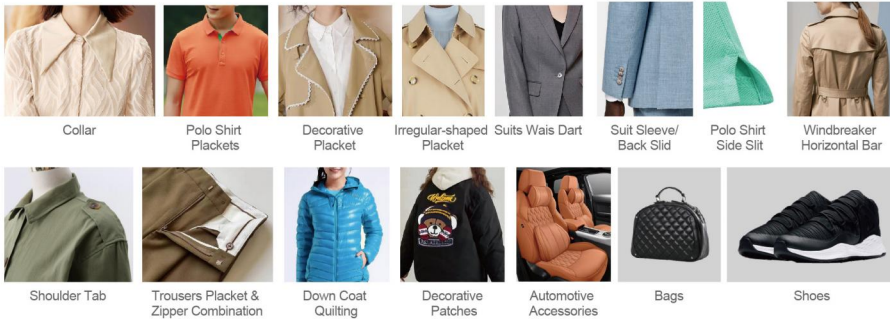

Optional information:

Optional	D	B	J	QX	ZM	BXZL	ZS
	Electronic presser foot	Brush	Laser	Rotated cutter	Automatic mold change	Upper thread tension (Third tensioner)	Automatic hook change
JK8110A-8045	★	●	■	■	○	●	●
JK8510A-3830	★	○	○	■	○	○	○
JK8220A-12080	★	●	■	■	○	●	●
JK8310A-13085	★	●	■	■	●	●	●
JK8310A-160105	★	●	○	●	○	○	●
JK8710A-13095	★	○	●	○	●	○	●

★ Standard ● Optional ○ Can not be installed ■ Cold knife and laser, only one can be added

Model detail:

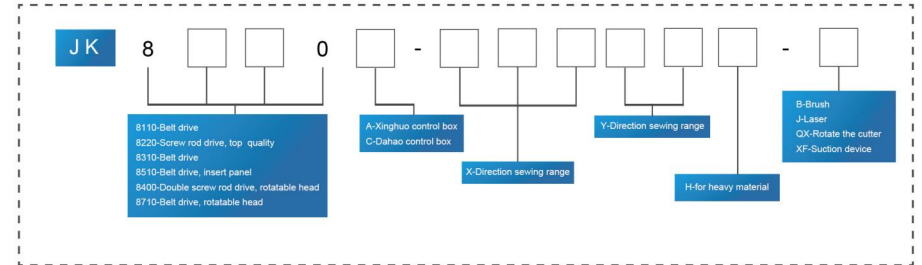

Model	Drive	mm	mm	mm	V	S.p.m.	mm	NW / GW Kg
JK8220A-12080H-SJ	DBx1 10#(7-14#)	0.5-12.7	20	4	550W 220V	3000	1470x1150x1270	190/267
JK8510A-3830-XF	DBx1 10#(7-14#)	0.5-12.7	20	4	550W 220V	3000	1530x1330x1470	235/340
JK8110A-8045	DBx1 10#(7-14#)	0.5-12.7	20	4	550W 220V	3000	1530x1330x1470	325/390
JK8400A-6055H	DBx1(#11) 9-18#	0.1-16.7	20	8	750W 220V	2000	1530x1330x1470	330/395



JK1790E-L02 前门襟锁眼机

Shirt front placket button holing machine

Auto feeding system, auto loading system, shirt can be positioned during previous part stitching time; Feeding direction programmable; 1 operator can use 2 machines; No skilled worker required.



JK1790E-L02	DPx5 11J-14J#	≤25mm	≤810mm	X: 220-420mm Y: 480-880mm	0.5Mpa	3600	2300x1100x1500	353/400



JK-113A 自动袖叉机

Automatic sleeve placket setter machine

This machine replaces the multiple processes such as manual folding, ironing, positioning and sewing in traditional sleeve placket production, achieves the integration of the entire process of "feeding+folding+sewing". No need skilled workers, one worker can operate two machines simultaneously, and the output of two machines can reach 3000 sleeves in 8 hours.



JK-113B

JK-113A	DBx1	X: 2.0/2.2/5/2.8/3.0cm Y: 20cm	Equipped	0.1-6mm	2machines	0.5Mpa 1.8L/min	2500	1030x1220x1730	395/450



JK1903ASS-L01 前门襟钉扣机

Shirt front placket button attaching machine

Auto loading, auto feeding, auto button holing, auto stacking mechanism; Fabric pre-loading mechanism; High-quality products making, production capacity 35% higher than similar products, the efficiency of ordinary sewing is more than 11 times; Easy for operation, 1 worker operates 2 machines simultaneously; Placket button holing sewing direction changeable.



JK1903ASS-L01	DPx17	Dia9-20mm	≤50mm	≤650mm	2-20pcs	0.5Mpa	2700	2300x1420x1500	322/400



JK-155TD 自动贴袋机

Automatic patch pocket machine

Suit for jeans, casual pants, uniforms, work clothes, T-shirt, skirt etc, it can sew pockets with all kinds of shapes, such as round, square, curved asymmetric pocket, and also be used to sew leather tags, bright lines of pocket cover and decorative pocket etc.

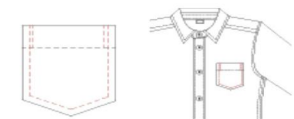

JK-155TD	DBx1 10# 11# 12#	0.05-12.7mm	0.5-0.6Mpa	max.28mm	max.200x215mm min.75x75mm	3500	1850x1050x1580	580/670



JK-720TD 自动贴袋机

Fully automatic non-ironing patch pocket sewing machine

This machine is suitable for multiple pockets, change pocket mold quickly and equip with loosen device. Pocket corner reinforcement device (optional)

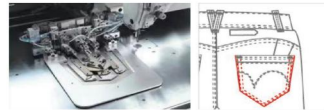

JK-720TD	DBx1 10# 11# 12#	0.05-12.7	0.5Mpa	28mm	230x230mm	2700	1700x1400x1500	430/460



JK254 双针自动订襟机

Automatic double needle belt loop sewing machine

This machine has a fast operating system and a fully visualized human-machine interface. Automatic detection device can screen out the waste at the crotch joint, and realize automatic screening and cutting. Streamlines procedures off workers, including cutting belt, bar-tacking carrying. Not only save the salary of workers but also improve efficiency by 70%.

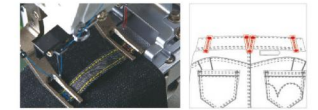

JK254	DBX17 19-21#	7-20	45.0-75	5.0-22.0	0.5Mpa 1.8L/min	2700	1220x800x1350	200/230



JK2210G-DH-AFC 自动缝袋花机

Automatic pocket decorative machine

The machine is mainly used for pocket decorative stitch sewing for work wear, jeans and casual wear. The electronic tricks equipped in the machine head can sew all kinds of tacking and decorative stitches in addition to common plat sewing stitches. The range of sewing is 220mm×100mm, which can be used to sew all kinds of pocket decorative stitches.

An average of 3,200 pockets can be produced in 8 hours, equals 1600 jeans in 8 hours.



JK2210G-DH-AFC	DPx5 14#	1	220x100	0.05-12.7	★	★	25	2800	1220x1000x1400	175/230



JK2000C-DD-A 裤耳缝卷一体机

Belt loop sewing and rolling integrated machine

Sewing and rolling integrated, match with belt loop sewing machine JK254, work faster, more convenient and cleaner.



JK2000C-DD-A	UY 128GAS 14-18#	2	3	1/4"	8	4500	1220x850x1500	110/130



JK-V536 自动卷口袋机

Automatic pocket hemming machine

The pocket folding and sewing can be done in one step, especially for elastic denim fabrics. No work skills required, productivity reaches up to 800 pockets per hour. The efficiency is increased to 3 times compared with the traditional procedure.



					Stitch type				
JK-V536	TVx5/18	2/3	1.4-4mm	1/4" (6.4mm) as standard 1/8" (3.2mm) or 3/8 inch (10mm)	Chainstitch	550W	5000	1150x850x1200	160/230



JK-M5011 牛仔裤裁片自动包边单元

Automatic overlock machine for jeans single piece

No need for skilled operation. Automatic disconnection detection stop function, which can guarantee the sewing effect in real time and ensure the safe operation of the equipment.

Serging front and back trousers (8 seams per trousers) : 750 -800 trousers/480min;

Serging front trousers with knee lining (4 seams per trousers): 650 trousers /480min;

Serging complete trousers with knee lining (8 seams per trousers): 450 trousers/480min



JK-M5011	2/3	3/4	0.5Mpa	550-750W	6,500	980x139x380	110/220



JK3883P-PLB-DK 自动卷口袋机

Automatic pocket hemming machine for jeans

Automatic pocket edge curling without any edge exposed; Width of curling edge is adjustable, with needle gauge 1/8", 1/4", 3/8" for option; Auto cutter and auto stacker; The efficiency is increased to 3 times compared with the traditional procedure; No work skills required; Productivity reaches up-to 800 pockets per hour.

JK-3883P-PLB-DK with build-in puller

JK-3883P-EPL-DK with electronic type puller



					Stitch type				
JK3883P-PLB-DK	TVx7 / 14-21	2	1.4-4mm	1/4" (6.4mm)	Chainstitch	5.5-10	4000	1320x1010x1300	160/200
JK3883P-EPL-DK	TVx7 / 14-21	2	1.4-4mm	1/4" (6.4mm)	Chainstitch	5.5-10	4000	1320x1010x1300	160/200



JK8842UTC 自动贴袋盖机

Automatic pocket facing machine

No skilled operators required. During the stacking action, the operator can focus on the next pocket, no need to stack by hand. Easy understandable touchscreen interface for all settings. Presser foot with side guide for facing, to ensure a correct edge covering. Pneumatic type trimmer with automatic stop function to save thread.



JK8842UTC	UY128GAS	1.4-4.0mm	7.4mm	400-550 pockets/h	5.5Bar/-L/min	220-240V 50/60HZ	5,500	1200x630x1040	110/175



JK2210MJ-ASN 牛仔门襟机

Automatic J type placket sewing machine

Equipped with LED light and automatic thread break sensor. The automatic feeding device and receiving device improve the production efficiency greatly. Worker can carry on the program according to the different requirements. Suitable for the J placket line processing of jeans, casual pants, overalls etc.



Model	DPx5	Needles	Table Size (mm)	Speed (S.p.m)	Production (pairs in 8 hours)	Presser Foot (mm)	Spinning (S.p.m)	Table Size (mm)	NW/GW (Kg)
JK2210MJ-ASN	DPx5 14#	1	200x100	0.05-12.7	2500pairs in 8 hours	25	2700	1140x1350x1400	280/310
JK3020MJ-ADN	DPx5 18#	1	300x200	0.05-12.7	2500pairs in 8 hours	25	2700	1140x1680x1400	320/350



JK7103WB 全自动裤腰折缝机

Automatic waistband folding and sewing machine (imitation handmade)

The specialized multi-positioning structure is able to control the waistband folding position more accurately, and the sewing process can be done in one-stage processing. The output of this machine with one ordinary worker in the same time is equivalent to the workload of 3-5 skilled workers.



Model	DPx7-19/120	Air pressure	Speed (S.p.m)	Table Size (mm)	NW/GW (Kg)
JK-V7100	DPx7-19/120	220V	2800	1400x850x1450	225/285



JK1104PRD-UTC 自动上腰机

Automatic waistband attaching machine

Suitable for sewing jean and casual pants waistband. With the function of needle feeding, auto skip stitch, auto fabric cutting and auto curve waistband.

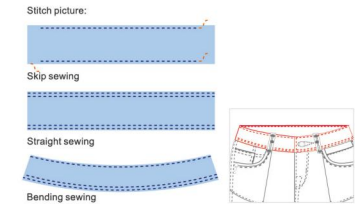

Model	TVx5 #21	Needles	Presser Foot	Table Width (mm)	Production (pcs in 8 hours)	Presser Foot (mm)	Spinning (S.p.m)	Table Size (mm)	NW/GW (Kg)
JK1104PRD-UTC	TVx5 #21	4	8	1/8"	2000pcs in 8 hours	10	4000	900x570x1400	106/137



JK63972-D4 电子辮脚机

Electronic bottom hemming machine

Auto thread trimmer, auto presser foot lifter, auto sweep thread and curling folder, use synchronous feeding device, upper-lower puller and needle feeding to prevent the dense stitch on joint, cylinder bed is more suitable for sewing hemming on trousers, dense stitch when edging to prevent offline. Interchange between lockstitch and chainstitch, realize two different stitches by change the hook and looper to meet the demands of different processes, suit for hemming of jeans, casual pants and other trousers.



Model	Stitch	Needles	Presser Foot	The width of hemming (mm)	Presser Foot (mm)	Spinning (S.p.m)	Table Size (mm)	NW/GW (Kg)
JK63970-D4	Lockstitch	DPx5	1	2	1/2"	8	940x800x1280	94/127
JK63971-D4	Chainstitch	DVx57	1	2	1/2"	8	940x600x1280	94/127
JK63972-D4	Lockstitch/Chainstitch	DPx5/DVx57	1	2	1/2"	8	940x800x1280	94/127



JK1008-311-9T 全自动开袋机

Automatic pocket welting machine

This machine sets automatic folding, laser bag opening and knot sewing in one, suitable for all kinds of real and fake pocket, single-layer pocket, double lips pocket, zipper pocket, side pocket etc. Avoid changing mold frequently, reduce mold changing time and improve production efficiency.

The finishing time for one pocket:

- Single needle sewing: 30 seconds per piece
- Double needle sewing: 20 seconds per piece

Output per hour:

- Single needle sewing: 180 pieces
- Double needle sewing: 120 pieces

JK1008T-311-9T	DPX17/ MT-90	0.1-12mm	X: 40-220mm Y: 7-35mm	25	15-35second/pcs	2800	1910x1350x1650 900/1100



JK-A02AF 全自动POLO衫门襟机

Automatic polo placket sewing machine (for Polo shirt front placket)

With microcomputer control, intelligent touch screen, automatic feeder.

Single/double cutters with dual-shaft structure can be installed and selected, and the position of the lower cutter is controlled digitally, running smoothly, with less wear and tear. With laser light marking positioning, accurately lock the position of the fabric to be processed.



JK-A02AF	DBx1 (10# 11# 12#)	1-5mm	50x320mm	3-8 seconds/piece	0.5-0.6MPa (5-6kgf/cm ²)	4000	1680x950x1450	300/373



JK-PS3520F 半自动激光开袋机

Semi automatic pocket welting machine

Suitable for universal thickness of fabric, can be used for pocket opening of trousers, denim, uniforms, down jackets, cotton clothes, jackets, waistcoats, casual pants etc. One machine with multiple functions, opening pockets, open plackets or pattern sewing (clamp needs to be replaced). It can produce 1000 pockets in 8 hours.



JK-PS3520FMJ For front placket
JK-PS3520F For pocket welting

JK-PS3520F	DPX17 18#	360*200mm	32	30-35second/pcs	0.5Mpa 1.8L/min	2700	1700x1140x1430	250/300
JK-PS3520FMJ	DPX17 18#	360*200mm	32	30-35second/pcs	0.5Mpa 1.8L/min	2700	1700x1140x1430	250/300



JK4800-356DK 全自动下摆机 (单片)

Automatic bottom hemming machine (for T-shirt bottom, single piece)

Designed for hemming T-shirt hems, cuff hems, and other single-piece sewing applications required hems on various garments. It can sew 8 pieces per minute, complete 4,800 pieces in 10 hours, increasing production efficiency by 40% compared to traditional process.

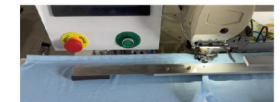

JK4800-356DK	UY128GAS 11-14#	3	5	5.6mm	1.4-4.5	7	5000	2050x1160x1450 210/250



JK343-RCA 全自动上圆领机

Fully automatic round collar attaching machine

This machine reduces reliance on skilled workers and specialized expertise, shortening training cycles and lowering labor costs. Additionally, it features precise automation technology, ensuring stable operation, reducing rework rates, and boosting production efficiency.



Icon	Production capacity	Round neck extension length	Air pressure	Icon	S.p.m.	Icon	NW/GW Kg				
	JK343-RCA	160-210pcs/hour	510-860 mm		0.6Mpa 130L/min		220V 750W	5500		1170x970x1780	174/245



JK-200E-HCS 自动拼橡胶筋

Automatic elastic ribbon splicing machine

All elastic processing procedures: auto feeding, cutting, stitching and collecting can be done by one button push operation. One operator can look after 4-6 sets of machines at the same time. 8000-12000pcs elastic can be stitched/8h/set.



Icon	Production capacity	Stretchable diameter range	Waistband Width	Air pressure	Icon	mm	NW/GW Kg		
	JK-200E-HCS	200-250pcs/hour	38-82cm	1.3-3.5cm		0.6bar	1000w 220V 50hz	1350x1000x1510	170/230



JK-Q310 自动下摆机

Automatic bottom hem machine

Automatic size identification, assorting and controlling. Automatic start-stop, thread trimming, align overlapping stitches. With seam position detection device for locating the position of start& end stitching and avoid false detection for fabric colour as well. The seam control mechanism can realize the both side into real same seam direction.

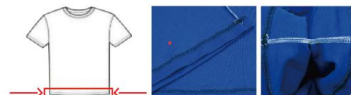

Icon	Icon	Icon	Needles number (max)	Sewing area (mm)	Stitch number can be stored	Pattern number can be stored	Air pressure	Icon	S.p.m.	Icon	NW/GW Kg			
			JK-Q310	DPx5 17#	10	10000/pattern	10-70mm	60000	999	0.5Mpa 1.8L/min	19	2000	1220x1220x1600	300/350



JK-Q375S 自动底裤上橡筋机

Automatic underpants elastic waistband attaching machine

Suitable for knitted underpants elastic ribbon band sewing. The left feeding roller ensure the fabric and tooth synchronous to convey smoothly. 2 sets of rectifying devices control the body edge more sensitive and stable, ensure the overlapped stitch and seam allowance consistent. Extend the suitable range for the regular radian unit.

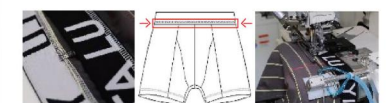

Icon	Production capacity	Stretchable diameter range	Waistband Width	Air pressure	Icon	mm	NW/GW Kg		
	JK-Q375S	150-180pcs/hour	28-60cm	1.5-6cm		0.6bar	220V, 50Hz	1220x970x1580	205/255

MEETLIN GROUP 20TH ANNIVERSARY EDITION 2005-2025



LOCKSTITCH SEWING MACHINE SERIES



JK-ML5 新款智能电脑平缝机
New intelligent lockstitch sewing machine
(single step motor)



JK-ML10 新款智能电脑平缝机
New intelligent lockstitch sewing machine
(double step motor)



JK500-1S9 大空间单步进电脑平缝机
Single step motor drive lockstitch sewing machine



JK200-1SB 单步进电脑平缝机
Single step motor drive lockstitch sewing machine



JK600-D4 电脑平缝机
Computerized lockstitch sewing machine



JK200-D4 电脑平缝机
Computerized lockstitch sewing machine

	Icon	mm	mm	mm	AUTO	L	M	H	mm	S.p.m.	mm	NW/gw Kg
JK-ML5		DBx1 14-22#	5	★	★	★	★	-	5.5-13	5000	680x245x523	40/48
JK-ML10		DBx1 14-22#	5	★	★	★	★	-	5.5-13	5000	680x245x523	40/48
JK500-1S6		DBx1 14-22#	5	★	★	★	★	-	5.5-13	5000	680x245x523	40/48
JK200-1SB		DBx1 14-22#	5	★	★	★	★	-	5.5-13	5000	620x285x550	36/42
JK600-D4		DBx1 14-22#	5	★	★	★	★	-	5.5-13	5000	680x245x523	37/44
JK200-D4		DBx1 14-22#	5	★	★	★	★	-	5.5-13	5000	620x245x540	31/38



JK-ML1 直驱平缝机
Direct drive lockstitch sewing machine



JK-ML2 直驱单剪线平缝机
Direct drive lockstitch sewing machine



JK777EC-1S 单步进带刀平缝机
Single step motor lockstitch machine with edge cutter



JK5490EC-4 差动带刀平缝机
Differential feed lockstitch machine with edge cutter



JK600-D1 直驱平缝机
Direct drive lockstitch sewing machine



JK600-D2 直驱单剪线平缝机
Direct drive lockstitch sewing machine



JK5200DDI-4 电脑带刀平缝机
Computerized lockstitch machine with edge cutter



JK777M-D4 电脑带刀平缝机
Computerized lockstitch machine with edge cutter



JK200-D1 直驱平缝机
Direct drive lockstitch sewing machine



JK200-D2 直驱单剪线平缝机
Direct drive lockstitch sewing machine



JK5200DD 直驱带刀平缝机
Direct drive lockstitch machine with edge cutter



JK777T-B 直驱切包一体平缝机
Direct drive lockstitch machine with package edge cutter

Model	DBx1	mm	L	M	H	mm	S.p.m.	mm	NW/gw Kg
JK-ML2	DBx1 14-22#	5	★	★	-	5.5-13	5000	680x245x523	37/44
JK9100DD	DBx1 14-22#	5	★	★	-	5.5-13	5000	620x250x565	32/39
JK600-D1	DBx1 9-18#	5	★	★	-	5.5-13	4500	630x250x540	35/38
JK600-D2	DBx1 9-18#	5	★	★	-	5.5-13	5000	630x250x540	36/39
JK200-D1	DBx1 11-18#	5	★	★	-	5.5-13	5000	625x245x540	31/35
JK200-D2	DBx1 11-18#	5	★	★	-	5.5-13	5000	625x245x540	32/36

Model	DBx1	mm	L	M	H	mm	S.p.m.	mm	NW/gw Kg
JK777EC-1S	DBx1 11#-18#	5	★	★	★	5.5-15	5000	630x257x570	35/42
JK5490EC-4	DBx1 11#-18#	5	★	★	★	5.5-15	5000	630x257x570	35/42
JK5200DDI-4	DBx1 11#-18#	5	★	★	★	5.5-8.5	4500	620x250x560	38/40
JK777M-D4	DBx1 11#-18#	5	★	★	★	5.5-8.5	4500	635x255x565	38/45
JK5200DD	DBx1 11#-18#	5	-	-	-	5.5-8.5	4500	600x230x550	32/35
JK777T-B	DBx1 11#-18#	5	-	-	-	5.5-8.5	4500	635x255x565	33/41



JK5492-1S-X-FOF

电脑上下差动平缝机

Variable top and bottom differential feed lockstitch machine

The bottom differential electronic adjustment allows one-click switching between flat sewing mode and differential mode. With segmented differential feed programming (up to 9 segments).



JK6492-1ST-OF-SA

小嘴差动电脑平缝机(机头无油)

Cylinder bed variable top differential feed lockstitch sewing machine

Use stepper motor shaft to connect the differential parts directly, and complete the action of changing the differential. Suitable for different fabrics, such as general fabric, non-ironing fabric, chiffon, velvet fabric etc.



JK303-1SB

步进电脑上下送料平缝机

Computerized up and bottom feed lockstitch sewing machine (single step motor)

The step motor controls the stitch distance accurate to 0.1mm. Turn on the dense stitch function to add one dense stitch before trimming (or add more stitches) to keep the thread end on the cloth after trimming.



JK6303-D4S

小嘴步进电脑上下送料平缝机

Computerized up and bottom feed lockstitch sewing machine (single step motor)

Use small cylinder type working platform. Suitable for sewing medium-heavy materials, such as soccer balls, bags, leather garments, leather goods, and sofas.



Model detail:

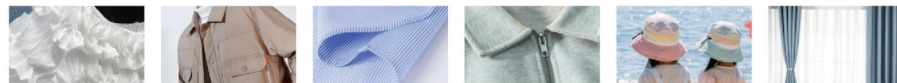
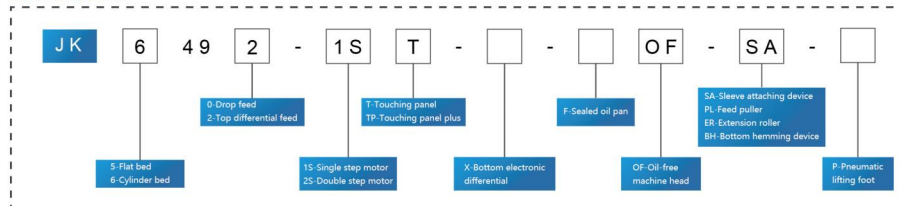

Model	Needle	Presser	Stitch	Motor	Speed (S.p.m.)	Dimensions (mm)	NW/GW (Kg)
JK5492	DBX1 7-18#	0-4	★	★	5/13	31.8	4,000 650x270x550 48/48
JK6492	DBX1 7-18#	0-4	★	★	5/13	31.8	4,000 650x245x550 48/50



JK0303DD



JK0303DDI-4



JK0356-D4/JK0385-D4
560/850mm

Model	Needle	Presser	Stitch	Motor	Speed (S.p.m.)	Dimensions (mm)	NW/GW (Kg)
JK303-1SB	DBX17 18-23#	2	10	★	★	★	6-13 2500 750x255x490 41/48
JK6303-D4S	DPX17 20-24#	4	8	★	★	★	8-16 2500 750x255x490 40/45
JK0303DDI-4	DBX17 22#	2	9	★	★	★	6-13 2500 580x250x530 35/42
JK0303DD	DPX17 22#	2	9	-	-	★	6-13 2500 580x250x530 29/35
JK0356-D4	DPX17 18-24#	2	8	★	★	★	6-13 2500 1020x460x400 63/75



The powerful compound feeding system including feed dog feeding, needle feeding and alternating presser foot feeding, guarantees feeding material freely without shift.

JK867-121226 电脑单针综合送料平缝机

Computerized single needle compound feed sewing machine

Model detail:

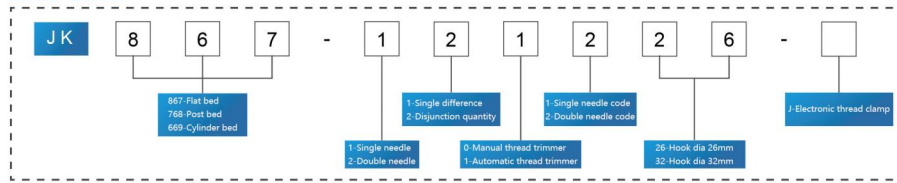

JK868 series

JK669 series



Fully automatic lubrication system, large hook, safety clutch, dial for alternating movement. With automatic alternating movement stitch compensation function. Suitable for sewing leather products, sofa, bag, car upholstery etc.

JK1560N-7D 电脑双针综合送料平缝机

Computerized double needle compound feed sewing machine



JK1510N-7D



Fully automatic oil lubrication system, large hook, synchronized cutting and binding, easy operation, excellent performance. Suit for binding mattress, quilting, car seat, upholstery, traveling bag, sports requisites, etc.

JK1510N-D-AE 直驱单针综合送料自动切包一体机

Direct drive single needle compound feed sewing machine with auto cutting and binding



JK1510N-AE



Fully automatic lubrication system, large hook, safety clutch, dial for alternating movement. With automatic alternating movement stitch compensation function. Suitable for sewing leather products, sofa, bag, car upholstery etc.

JK1510NL-46 460x105mm JK1560NL-46 460x105mm
JK1510NL-65 650x105mm JK1560NL-65 650x105mm
JK1510NL-101 1000x105mm JK1560NL-101 1000x105mm

JK1560NL-65-7D 电脑双针综合送料平缝机

Computerized long arm single needle compound feed sewing machine



JK1510NL-46-7D



Model	Table Size	Table	Presser	Needle	Foot	Stitch	Speed	Table	Speed	NW/GW
			mm	mm		(mm)	S.p.m.	mm		Kg
JK867-121226	DPx35	90-180	2/4	12	36	★	20	355x125	3000	745x370x705 68/74
JK768H-2-7	DPx17	19-23#	4-8	9	36	★	9/16	255x130	2000	720x320x720 50/52
JK1510N-D-AE	DPx17	19-23#	4-8	9	36	-	9/16	255x105	2500	730x370x720 55/60
JK1510N-AE	DPx17	19-23#	4-8	9	36	-	9/16	255x130	2000	720x320x720 55/60

Model	Table Size	Table	Presser	Needle	Foot	Stitch	Speed	Table	Speed	NW/GW	
			mm	mm		(mm)	S.p.m.	mm		Kg	
JK1560N-7D	DYx17	19-23#	2	9	36	★	9/16	255x105mm	550	2500	770x330x720 60/55
JK1510N-7D	DYx17	19-23#	1	9	36	★	9/16	255x105mm	550	2500	770x330x720 60/55
JK1560NL-65-7D	DYx17	19-23#	2	9	36	★	9/16	650x105mm	550	2500	1170x330x720 90/95
JK1510NL-46-7D	DYx17	19-23#	1	9	36	★	9/16	460x105mm	550	2500	1170x330x720 60/65



JK20606L-1-64 635x150mm
 JK20606L-2-64 635x150mm
 JK20606L-1-76 760x150mm
 JK20606L-2-76 760x150mm
 JK20606L-1-102 1015x100mm
 JK20606L-2-102 1015x100mm

JK20606DD-2N-4 电脑双针综合送料平缝机

Computerized double needle compound feed lockstitch sewing machine

Needle gauge size: 3.2/4/4.8/6.4/9.5/12.7/16/19/25.4mm

Suitable for sewing such as products as sofa, suitcase, car seats, etc.

Model detail:

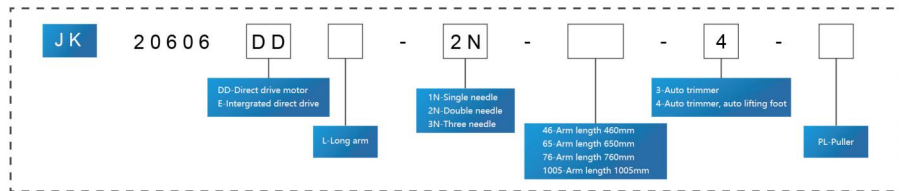

JK20606DD-2N



JK20606DDL-1N-46-7



JK20606L-1-76

Model	Needle	Needle Gauge (mm)	Arm Length (mm)	Needle Gauge (mm)	Speed (S.p.m.)	Dimensions (mm)	NW/GW (kg)
JK20606DD-2N-4	DPX17 19-23#	2	9	36	★	8/13 2000 670x350x635	40/50
JK20606DD-2N	DPX17 19-23#	4	9	36	★	8/13 2000 670x350x635	40/50
JK20606DDL-1N-46-7	DPX17 19-23#	2	9	36	★	8/13 1200 670x350x635	40/50
JK20606L-1-76	DPX17 19-23#	4	9	36	★	8/13 1200 670x350x635	40/50



JK8752E 新款电脑双针平缝机

Computerized double needle lockstitch machine, with auto trimmer, large hook, split needle bar

The machine has structure of twin-needle and split needle bar. It's very convenient to make corner seam, acute angle seam and straight seam, and to sew two parallel lockstitch of any angle. It's suitable for decoration and corner seaming of undershirt, ladies' underwear, jeans wear, overcoat, etc.

Model detail:

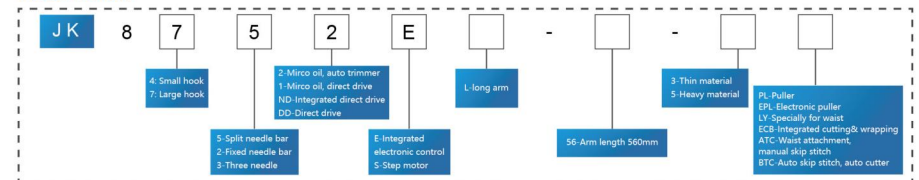

JK8422S



JK8422E



JK842ND



JK8431

Model	Needle	Needle Gauge (mm)	Arm Length (mm)	Needle Gauge (mm)	Speed (S.p.m.)	Dimensions (mm)	NW/GW (kg)
JK8452S	DPX5 11-12#	2	4	5	1/8 (3.2mm)	★ / 7-13 4000 730X320X670	50/58
JK8752E	DPX5 11-12#	2	4	5	5/32 (4.0mm)	/ ★ 7-13 4000 730X320X670	50/58
JK8452E	DPX5 11-12#	2	4	5	3/8 (9.6mm)	/ ★ 7-13 3000 670X350X650	40/49
JK872ND	DPX5 11-12#	2	4	5	1/4 (6.4mm)	/ ★ 7-13 4000 740x310x625	43/54
JK842ND	DPX5 11-12#	2	4	5	5/16 (8mm)	/ ★ 7-13 3000 670x350x650	40/49

MEETLIN GROUP 20TH ANNIVERSARY EDITION 2005-2025



OVERLOCK SEWING MACHINE SERIES



JK-MO7-4D-SUT 新款超高速智能包缝机
Intelligent super high speed overlock sewing machine



JK-MO7-4D 超高速直驱包缝机
Direct drive super high speed overlock sewing machine



JK-F910-4D-SUT 超高速智能包缝机
Intelligent super high speed overlock sewing machine





JK-F910-4D 超高速直驱包缝机
Direct drive super high speed overlock sewing machine



JK-F900-4D-SUT 超高速智能包缝机
Intelligent super high speed overlock sewing machine



JK-F900-4D 超高速直驱包缝机
Direct drive super high speed overlock sewing machine

										
MO7-4D-SUT	DCx27 11#	2	4	4	4.5	0.7-2	5.5	7000	400x335x480	28/33.5
JK-F910-4D-SUT	DCx27 11#	2	4	4	4.5	0.7-2	5.5	7000	400x335x480	28/33.5
JK-F910-4D	DCx27 11#	2	4	4	4.5	0.7-2	5.5	7000	400x335x480	28/33.5
JK-F900-4D-SUT	DCx27 11#	2	4	4	4.5	0.7-2	5.5	7000	400x335x480	28/33.5
JK-F900-4D	DCx27 11#	2	4	4	4.5	0.7-2	5.5	7000	400x335x480	28/33.5



JK-FT900-4D-EUT 新款智能差动包缝机
Intelligent up and bottom differential feeding overlock sewing machine (auto trimmer)



JK-FT900-4D 超高速直驱差动包缝机
Direct drive up and bottom differential feeding overlock sewing machine



JK-F10-4D 直驱4线包缝机
Direct drive overlock sewing machine



JK-F72-4D 直驱4线包缝机
Direct drive overlock sewing machine



EX5214DD-EUT 超高速自动剪线包缝机
Super high speed overlock machine (auto trimmer)



EX5214DD 超高速直驱包缝机
Direct drive super high speed overlock sewing machine



JK-F7-4D 直驱4线包缝机
Direct drive overlock sewing machine



JK752-13DD 超高速直驱包缝机
Direct drive 4 thread sewing machine



EX5114DD-EUT 超高速小嘴自动剪线包缝机
Cylinder bed super high speed overlock machine (auto trimmer)



EX5114DD 超高速直驱小嘴包缝机
Cylinder bed super high speed overlock sewing machine



JK6714S-DD 直驱4线包缝机
Direct drive overlock sewing machine



EXT5214DD 直驱差动包缝机
Direct drive 4 thread overlock sewing machine

	DCx27 (9-14#)	2	4	6	3.6	0.7-2.0	5.5	6500	470x350x480	34/37	
EX5214DD-EUT	DCx27 (9-14#)	2	4	6	3.6	0.7-2.0	5.5	6500	470x350x480	34/37	
EX5114DD-EUT	DCx27 (9-14#)	2	4	6	3.6	0.7-2.0	5.5	6500	470x350x480	34/37	
JK-FT900-4D-EUT	DCx27 (9-14#)	2	4	6	3.6	0.7-2.0	5.5	6500	470x350x480	34/37	
JK-FT900-4D	DCx27 (9-14#)	2	4	6	3.6	0.7-2.0	5.5	6500	470x350x480	34/37	

	DCx27 11#	2	4	-	4	4.5	0.7-2.0	5.5	7000	400x335x480	28/33.5
JK-F10-4D	DCx27 11#	2	4	-	4	4.5	0.7-2.0	5.5	7000	400x335x480	28/33.5
JK-F72-4D	DCx27 11#	2	4	-	4	4.5	0.7-2.0	5.5	7000	400x335x480	28/33.5
JK-F7-4D	DCx27 11#	2	5	-	4	4.5	0.7-2.0	5.5	7000	400x335x480	28/33.5
JK752-13DD	DCx27 11#	2	5	-	4	4.5	0.7-2.0	5.5	7000	400x335x480	28/33.5
JK6714S-DD	DCx27 11#	2	5	-	4	4.5	0.7-2.0	5.5	7000	400x335x480	28/33.5
EXT5214DD	DCx27 11#	2	5	-	4	4.5	0.7-2.0	5.5	7000	400x335x480	28/33.5



SMK: Elastic attaching
Electric metering type elastic tape feeding
EX5114DD-SMK
EXT5114DD-SMK
JK-F900-4D-SUT-SMK

LFC: Elastic attaching
Tape feeding device control the tension
JK737F-504M2-04-LFC
JK747F-514M2-04-LFC
EX5204DD-LFC
EX5214DD-LFC
For 3&4 thread overlock machine

RLK2: Tubular extending roller set
Extending by pneumatic
EX5114DD-RLK2
EXT5114DD-RLK2
EX5114DD-KS-RLK2
EXT5114DD-KS-RLK2



RLK3: Tubular extending roller set
Auto extending
EX5114DD-KS-RLK3
EXT5114DD-KS-RLK3

RLKA: Tubular extending roller set
Auto extending
EX5114DD-RLKA
EXT5114DD-RLKA

RLKA2: Tubular extending roller set
Auto extending
EX5114DD-RLKA2
EXT5114DD-RLKA2



GA: Gathering
JK 757F-516H4-35-GA
JK 757F-514H4-24-GA
M732-48GA
EX3216DD-GA

FG: Glove sewing
JK737FG-DD

BS: Blind stitch
EX5214DD-BS





JK-H7-01CB/SUT-WP

智能步进平台式绷缝机
Intelligent flat bed interlock sewing machine (single step motor, top wiper)



JK-H7-01CB

直驱平台式绷缝机
Direct drive flat bed interlock sewing machine



JK-H8-01CB/SUT-ST

智能小方头式绷缝机
Intelligent cylinder bed interlock sewing machine (single step motor, top and bottom trimmer)



JK-H8-01CB

直驱小方头式绷缝机
Direct drive cylinder bed interlock sewing machine



JK562E-01CB/SUT-WP

智能平台式绷缝机
Intelligent flat bed interlock sewing machine (single step motor, top wiper)



JK562E-01CB

直驱平台式绷缝机
Direct drive flat bed interlock sewing machine



JK664E-01CB/SUT-WP

智能小方头式绷缝机
Intelligent flat bed interlock sewing machine (single step motor, top wiper)



JK787DD-356/UT-WP

直驱款细横筒绷缝机
Direct drive small cylinder bed interlock sewing machine with top wiper



Top and bottom trimmer(ST) Top wiper(WP) Hidden outer thread cam Bottom



Pneumatic wire blowing device Step motor auto trimmer Dense stitch device Lower empty thread ring cutter device Presser foot lift (electronic or pneumatic) Pneumatic presser foot pressure regulation by precise cylinder

Model	Motor	Stitch	Needle	Presser	Stitch Length (mm)	Stitch Width (mm)	Stitch Density	Speed (S.p.m)	Dimensions (mm)	Weight (NW/GW Kg)
JK-H7-01CB/SUT-WP	UY128GAS 11#	3(2) 5(4)			4.8,5,6,6.4 2.4,3.2,4.0,4.8,5.6	4.4	-	0.5-1.3	5 6.3	5500 640x410x640 45/53
JK-H7-01CB	UY128GAS 11#	3(2) 5(4)			4.8,5,6,6.4 2.4,3.2,4.0,4.8,5.6	4.4	-	0.5-1.3	5 6.3	5500 640x400x630 44/52
JK562E-01CB/SUT-WP	UY128GAS 11#	3(2) 5(4)			4.8,5,6,6.4 2.4,3.2,4.0,4.8,5.6	4.4	★	0.5-1.3	5 6.3	5500 640x400x630 52/60
JK562E-01CB	UY128GAS 11#	3(2) 5(4)			4.8,5,6,6.4 2.4,3.2,4.0,4.8,5.6	4.4	-	0.5-1.3	5 6.3	5500 640x400x630 44/52

Model	Motor	Stitch	Needle	Presser	Stitch Length (mm)	Stitch Width (mm)	Stitch Density	Speed (S.p.m)	Dimensions (mm)	Weight (NW/GW Kg)
JK-H8-01CB/SUT-ST	UY128GAS 11-14#	3	5		5.6(6.4)	1.4-4.5	★	0.8-1.4	7.0	5000 610x410x640 55/58
JK-H8-01CB	UY128GAS 11-14#	3	5		5.6(6.4)	1.4-4.5	-	0.8-1.4	7.0	5000 610x410x640 55/58
JK787DD-356/UT-WP	UY128GAS 11-14#	3	5		5.6(6.4)	1.4-4.5	★	0.8-1.4	7.0	4500 610x410x640 55/58



JK562DD-01CB/UT-WP
自动剪线平台式绷缝机
Direct drive flat bed interlock sewing machine (auto trimmer, top wiper)



JK562DD-07CB
直驱3针7线平台式绷缝机
Direct drive 3 needle 7 thread interlock sewing machine



JK740DD-01-SUT
步进款曲臂型四针六线自动剪线拼缝机
Direct drive feed-off-the-arm 4 needle 6 thread sewing machine (step motor, single cutter, for heavy material)

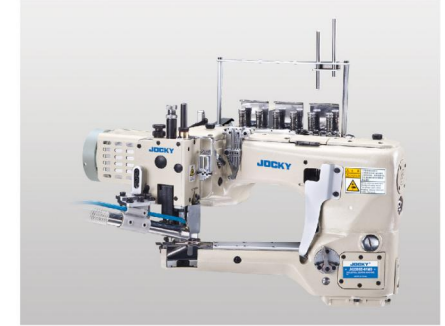

JK62GD-01
直驱曲臂式拼缝机
Direct drive 4-needle 6-thread feed-off-the-arm interlock sewing machine



JK664DD-01CB/UT-ST
高速筒形自动剪线绷缝机
Direct drive cylinder bed interlock sewing machine (auto trimmer)



JK664DD-35BB/UT-WP
直驱筒形自动剪线绷缝机
Direct drive cylinder bed interlock sewing machine (with left cutter, auto trimmer, top wiper)



JK1500DD/UT
竖筒式自动剪线绷缝机
Direct drive high speed feed-up-the-arm interlock sewing machine (auto trimmer)



JK1500DG-01CB-TK
直驱竖筒式绷缝机(上肩带, 带斩刀)
Direct drive feed-up-the-arm interlock sewing machine (for tape attaching and cutter)



JK562-05CB



JK562-02BB



JK562-04CB



JK664-01CB



JK664-02BB



JK664DD-33AC/UT



Single cutter, narrow blade.



Single cutter, wide blade.



Single cutter, wide blade, double cutter type plate.



JK740DD-01-SUT single cutter

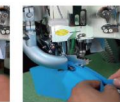

JK740DD-02-SUT double cutter



JK1500DG-01CB

Model	Needles	Threads	Stitch	Stitch Length (mm)	Stitch Width (mm)	Stitch Density (1/cm)	Stitch Density (1/in)	Speed (S.p.m)	Table Size (mm)	Max. Sewing Weight (kg)
JK562DD-01CB/UT-WP	UY128GAS 11-14#	3(2) 5(4)	3,2,4,0 (4,8,5,6,6,4)	1.2-4.0	1.0-5-11.3	6.3(5.0)	6000	600x410x630	42/52	
JK562DD-07CB	UY128GAS 11-14#	2 4	5,6,6,4	4.4	0.5-1.3	6.3	5000	600x410x630	42/52	
JK664DD-01CB/UT-ST	UY128GAS 11-14#	3(2) 5(4)	3,2,4,0 (4,8,5,6,6,4)	1.2-4.0	1.0-5-11.3	6.3(5.0)	6000	600x410x630	42/52	
JK664DD-35BB/UT-WP	UY128GAS 11-14#	2 4	5,6,6,4	4.4	0.5-1.3	6.3	5000	600x410x630	42/52	

Model	Needles	Threads	Stitch	Stitch Length (mm)	Stitch Width (mm)	Stitch Density (1/cm)	Stitch Density (1/in)	Speed (S.p.m)	Table Size (mm)	Max. Sewing Weight (kg)
JK740DD-01-SUT	UY128GAS 11-14#	3(2) 5(4)	4,8,5,6,6,4 (3,2,4,0)	5.6-6.4	1.0-5-1.3	6.3(5.0)	6000	610x410x640	42/52	
JK62GD-01	UY128GAS 11-14#	3(2) 5(4)	4,8,5,6,6,4 (2,4,3,2,4,0,4,8)	1.2-4.4	1.0-5-1.3	6.3(5.0)	6000	610x410x640	42/52	
JK1500DD/UT	UY128GAS 11-14#	3(2) 5(4)	5,6,6,4 (3,2,4,0)	0.9-4.5	1.0-6-1.3	6.3(5.0)	6000	610x410x640	42/52	
JK1500DG-01CB	UY128GAS 11-14#	3(2) 5(4)	4,8,5,6,6,4 (3,2,4,0)	5.6-6.4	1.0-5-1.3	6.3(5.0)	6000	610x410x640	42/52	

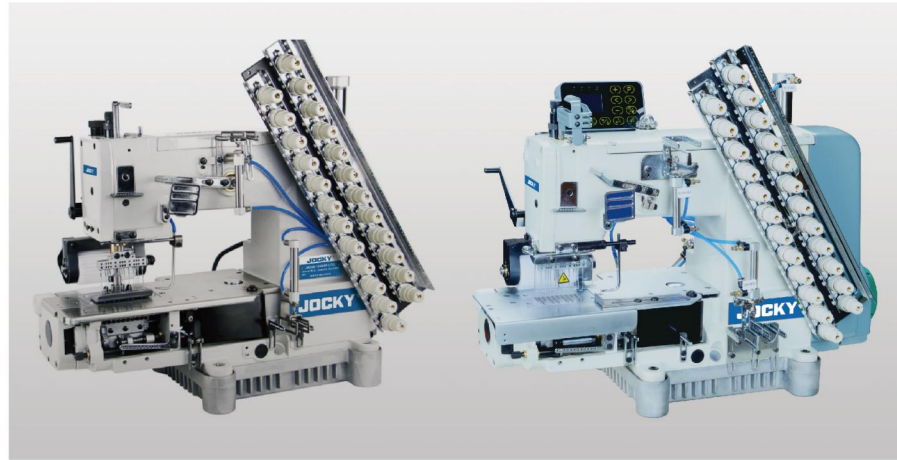

JK008-12064P-UTC 直驱自动剪线多针机

Direct drive multi-needle double chain stitch sewing machine (auto trimmer)

JK077C-12064P-PUT 直驱自动剪线多针机

Direct drive multi-needle double chain stitch sewing machine (auto trimmer)



JK1404PE 直驱平台型多针双重环缝机

Direct drive flat bed multi-needle double chain stitch sewing machine

JK4412P 半筒式多针双重环缝机

Cylinder bed multi-needle double chain-stitch sewing machine

STITCH SAMPLE OF JK008 SERIES MACHINE

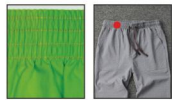

VWL: Elastic-feeding for waist sewing

JK008-04085P/VWL
JK008-08084P/VWL
JK008-12064P/VWL

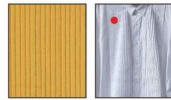

VPT: Pin tucking

JK008-12032P/VPT JK008-12048P/VPT
JK008-12064P/VPT JK008-25064P/VPT
JK008-33048P/VPT

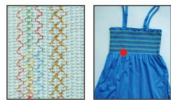

VPQ/VSM: Single elastic thread shirring sewing and smocking

JK008-12048P/VPQ/VSM JK008-12064P/VPQ/VSM
JK008-16048P/VPQ/VSM JK008-25048P/VPQ/VSM
JK008-25064P/VPQ/VSM JK008-33048P/VPQ/VSM
JK008-65048P/VPQ/SM-DD



VPL: Tape attaching

JK008-08064P/VPL
JK008-08064P/VPL
JK008-12064P/VPL

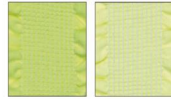

VPQ-T: Up elastic thread, no bottom thread

JK008-12048P/VPQ-T JK008-12064P/VPQ-T
JK008-16048P/VPQ-T JK008-18064P/VPQ-T
JK008-23048P/VPQ-T JK008-25048P/VPQ-T
JK008-25064P/VPQ-T JK008-33048P/VPQ-T



VSQ/VSM: Bottom elastic thread shirring sewing and smocking

JK008-12048P/VSQ/VSM JK008-12064P/VSQ/VSM
JK008-16048P/VSQ/VSM JK008-18064P/VSQ/VSM
JK008-25048P/VSQ/VSM JK008-25064P/VSQ/VSM
JK008-33048P/VSQ/VSM

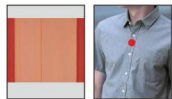

VSF: Shirt fronting attaching

JK008-0448-254P/VSF
JK008-0464-191P/VSF
JK008-0464-254P/VSF

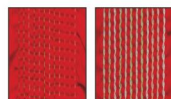

VSQ: Bottom elastic thread shirring sewing, Up normal thread

JK008-12048P/VSQ JK008-12064P/VSQ
JK008-16048P/VSQ JK008-18064P/VSQ
JK008-23048P/VSQ JK008-25048P/VSQ
JK008-25064P/VSQ JK008-33048P/VSQ

STITCH SAMPLE OF JK1404 SERIES MACHINE



PSF: Shirt front attaching

JK1404PSF

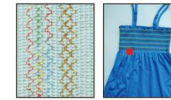

PSSM: Shirring and smocking stitch, up normal thread, bottom normal thread

JK1012PSSM JK1412PSSM
JK1025PSSM JK1425PSSM
JK1033PSSM JK1433PSSM
JK1050PSSM JK1450PSSM

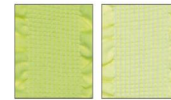

PS: Shirring stitch, up elastic thread, no bottom thread

JK1012PS
JK1025PS
JK1033PS

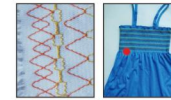

PSSM-ET-MD: Shirring and smocking stitch, up normal thread, bottom elastic thread, with front puller

JK1417PSSM-ET-MD
JK1433PSSM-ET-MD
JK1450PSSM-ET-MD

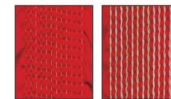

P-ET: Shirring stitch, up normal thread, bottom elastic thread

JK1412P-ET
JK1433P-ET
JK1450P-ET

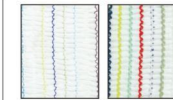

PS: Normal up and bottom thread, middle elastic thread

JK1412PQ
JK1425PQ
JK1433PQ



PL: Tape attaching

JK1408PL JK4406PL
JK1408PL JK4408PL
JK1412PL JK4412PL

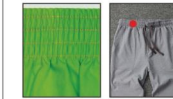

PMD: Elastic feeding for waistband

JK1404PMD JK4404PMD
JK1406PMD JK4406PMD
JK1408PMD JK4408PMD
JK1412PMD JK4412PMD



High speed, low air consumption, low defect rate, simple interface, automatic color change, multiple language (Chinese, English, Russian, Arabic etc.)

JK9813-508 Jeans button
JK9813-509AB Front side
JK9813-509CD Reverse side
JK9813V Vertical type



JK9813V

JK9918

JK9813 智能钉扣机(台板款, 带冲孔功能)
Intelligent button machine with punching function

Icon	Pressure	Power consumption	Size of Rhinestone	Number of disc	⚡	🌀	📏	NW/GW
					220V 50Hz	S.p.m.	mm	Kg
JK9813	0.5MPa	5W Static 220W Dynamic	2-7.5	Double disc	220V 50Hz	50pcs/min	1040x700x1400	140/170
JK9813V	0.5MPa	5W Static 220W Dynamic	2-7.5	Double disc	220V 50Hz	50pcs/min	1040x700x1400	140/170
JK9918	0.5MPa	5W Static 220W Dynamic	2-7.5	Double disc	220V 50Hz	60pcs/min	1040x700x1400	155/170



High speed, low air consumption, low defect rate, simple interface, automatic color change, multiple language (Chinese, English, Russian, Arabic etc.)

JK-DS90-XXG-1 Left side hook
JK-DS90-XXG-2 Right side hook



JK-DS80
Special for jeans

JK-DS90-SKG 全自动打扣机(西裤扣)
Automatic snap button machine (for trousers hook)

Icon	Working throat depth	Working height	Number of disc	Voltage	⚡	🌀	📏	NW/GW
					0.75KW	S.p.m.	mm	Kg
JK-DS90-SKG	55mm	25mm	Double disc	220V	0.75KW	180pcs/min	480X480X1310	140
JK-DS80	100mm	25mm	Single disc	220V	0.75KW	160pcs/min	480X480X1320	140



JK838T-360 电脑直驱拼钮机(360度旋转)
3 head electric snap attaching machine

Icon	Voltage	Eccentric distance	Stroke	📏	NW/GW
				mm	Kg
JK838T-360	220/380V 370W	19	38	535x360x330	23/25
JK3808E	220/380V 370W	19	38	535x360x330	23/25
JK818	220/380V 370W	19	38	535x360x330	23/25

This machine can be installed three sets of molds to work, one mold for punching the holes on the fabric, the other two molds for attaching the buttons, worker doesn't need to change the mold which will save time and increase productivity. Double protection mechanism by electronic and mechanic. With electronic counter, laser positioning lamp and bright LED light. Suitable for cowboy, shirt, jacket and other kinds of clothing, hats etc.



JK3808E

JK818



JK-2808S 气动电脑控制装钮机
Pneumatic snap attaching machine with time delay function

Pneumatic button attaching machine is driven by air with high efficiency, energy economy and safety environment protection. It can work normally even without power if with sufficient air pressure. The multi-headed button attaching machine could fix many button mould at one time and switch easily, so it is in favor of fixing various kinds button on one cloth at one time, adjust the reductor to change the press to avoid damage the plating on the button to keep the button firm and beautiful.



JK-DT9

JK-SQ1

Icon	Pressure	Fixing time	Voltage	Stroke	📏	NW/GW
					mm	Kg
JK-2808S	0.6-0.8Mpa	50pieces/minute	-	40	535X360X330	15/16
JK-DT9	-	50pieces/minute	220V 570W	-	550X350X450	39.9/44.6
JK-SQ1	0.4-0.6Mpa	50pieces/minute	-	-	535X360X330	15/16



High speed electronic button sewing machine, equipped with fully automatic feeding device which has the function of automatic recognition system. It is suitable for different standard sewing requirement. It is lock stitch and not easy to loose lines. Low machine failure rate, high efficiency, convenient system operation.



JK1903A-998S 自动送扣钉扣机 (视觉识别系统)
Automatic button attaching machine with auto button feeding device (automatic recognition system)



998 自动送扣装置 (旋转型气缸款)
Automatic button feeding device (electric type)



998A 自动送扣装置 (笔型气缸款)
Automatic button feeding device (pneumatic type)



998 自动送扣装置 (电机款)
Full automatic feeding device (electric type)



998S 自动送扣装置 (带视觉识别系统)
Automatic button feeding device (automatic recognition system)

	DPx17#	8-32	★	★	13	3000	1270x740x1300	90/130
JK1903A-998S	DPx17#	8-32	★	★	13	3000	1270x740x1300	90/130
JK1903ASS	DPx17#	8-32	★	★	13	3000	800x650x500	60/65

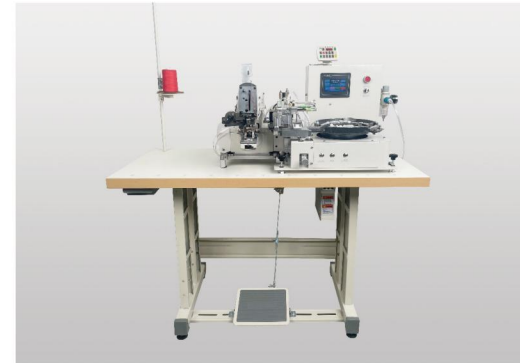

This machine is applicable for button with two or four holes, equipped with fully automatic button feeding device. It is suitable for light and weight material. Low machine failure rate, high efficiency, convenient system operation.



JK1377DD-XD988 自动送扣钉扣机
Automatic button attaching machine with auto button feeding device

	TQx1 14-18#	1	10-28	x(2.5-6.5) y(0.2.5-6.5)	⊖ ⊕ ⊗	★	★	>9	1500	1270x740x1300	90/130
JK1377DD-XD988	TQx1 14-18#	1	10-28	x(2.5-6.5) y(0.2.5-6.5)	⊖ ⊕ ⊗	★	★	>9	1500	1270x740x1300	90/130
JK1377DD	TQx7 20#	1	10-28	x(2.5-6.5) y(0.2.5-6.5)	⊖ ⊕ ⊗	★	★	>9	1500	505x330x415	43/45
JK1377	TQx7 20#	1	10-28	x(2.5-6.5) y(0.2.5-6.5)	⊖ ⊕ ⊗	★	★	>9	1500	580x440x430	30/43
JK1373S	TQx7 20#	1	10-28	x(2.5-6.5) y(0.2.5-6.5)	⊖ ⊕ ⊗	★	★	>9	1500	505x330x415	24/28.5



This machine is applicable for button with two holes, equipped with fully automatic button feeding device. It is suitable for light and weight material. Low machine failure rate, high efficiency, convenient system operation.

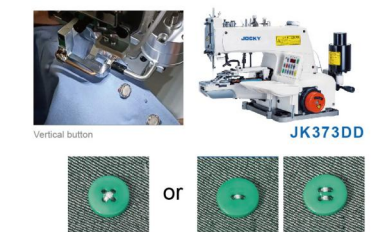

JK373DD-LK917 自动送扣钉扣机 (立扣)
Automatic button attaching machine with auto button feeding device (for vertical button)

	TQx1 14-18#	1	10-28	x(2.5-6.5) y(0.2.5-6.5)	⊖	★	★	>9	1500	1230x775x1350	105/125
JK373DD-LK917	TQx1 14-18#	1	10-28	x(2.5-6.5) y(0.2.5-6.5)	⊖	★	★	>9	1500	1230x775x1350	105/125
JK373DD	TQx7 20#	1	10-28	x(2.5-6.5) y(0.2.5-6.5)	⊖ ⊕ or ⊗	★	★	>9	1500	580x440x430	27/30.5
JK373	TQx7 20#	1	10-28	x(2.5-6.5) y(0.2.5-6.5)	⊖ ⊕ or ⊗	★	★	>9	1500	505x330x415	22/25



JK9820 圆头电子锁眼机

Eyelet button holing machine

The JK9820 is equipped with a liquid crystal display (LCD) and indicates display items with icons and letters, setting and check of sewing patterns and change of sewing modes are easy to understand and operate, the arm pocket of 120mm depth gives a sufficient space, enabling material setting smoothly. It is suitable for sewing vertical buttonholes and hip pocket parts. The arm shape provides a good view of the needle area, allowing workers to observe the sewing easily, the shape of the looper, the thread take-up amount and some other parts have been reviewed, skipped stitches and insufficient thread tightening due to a change of thread tension are reduced, regardless of types of threads, the range of sewing capability has been enlarged.

Sewing shape:



				Tail knot length				
JK9820-00	Dox558	1	5-50	0-20	★	16	2700	1250x800x1300
JK9820-01	Dox558	1	5-50	0-20	★	16	2700	1250x800x1300
JK9820-02	Dox558	1	5-50	0-20	★	16	2700	1250x800x1300



JK1790E 平头电子锁眼机

Straight button holing machine, complete set

By setting the sewing speed of the first 5 stitches on the control panel, the machine starts working at low speed, which can largely prevent thread breakage and fraying at the beginning of sewing.



JK1790E	DPx5 11-14#	1	2	10-220	2.5-9	550W 220V	14	4200	780x380x650	65/69
JK1790Q	DPx5 11-14#	1	2	10-220	2.5-9	550W 220V	14	4200	780x380x650	65/69



JK-B781F-2S 双步进平头锁眼机

Double step motor straight button holing machine

This machine applies to general button holing on all light to medium-heavy materials. It can sew flat stitch and triangle stitch with beautiful and solid seam. It is with high sewing speed, and its button holing size and stitch number are adjustable as well as button holing positioning can be easily adjusted.

JK-B781F-2S 6.35-19.5mm
JK-B782F-2S 6.35-25.4mm
JK-B783F-2S 6.35-31.8mm



JK-B781E	DPx5 11-14#	1	2	1	★	22x(2.5-4)	370	12	2600	700x370x520	53/57
JK-B781F-2S	DPx5 11-14#	1	2	1	★	22x(2.5-4)	370	12	3200	700x370x520	53/57



JK6000S 电脑假眼机

Computerized imitation button holing machine

Oil-free structure of the whole machine. Stitch size, length, distance and etc are electronically controlled. Easy setup for numbers and distance of button holes due to the auto feeder. Button hole of each sewing cycle can set 1-8.

JK6000S for straight and slanted button hole.
JK6000D for straight type button hole only



				Hole length	Lubrication				
JK6000S	EB750 10-16#	1	15-25mm	Spindle	550-750	1500-3500	1220X720X1180	120/155	
JK6000D	EB750 10-16#	1	15-25mm	Spindle	550-750	1500-3500	1220X720X1180	120/155	



This machine can make attractive seams at high speed which combines high quality sewing and high productivity. It's easy to operate. The machine can be used on various materials from light to heavy fabric, such as underwear, knitted fabrics and jeans.

- JK430D Touch-tone panel
- JK430D-01 For medium heavy material
- JK430D-02 For heavy material
- JK430DT Touching panel
- JK436D Bartacking area 60x90mm



JK430DT 电子套结机

Electric bar tacking machine

JK430D/JK430DT	1	0.05-12.7	★	★	★	★	★	17	3200	800x650x500	60/65



This machine is applicable to sew bar tacks at garment's parts where needs enforced. By controlling operation panel, you can select required sewing speed, sewn patterns and increase or reduce seam size. Special patterns are also can be realized such as umbrella circular track and suit's decorative button hole.

Options:

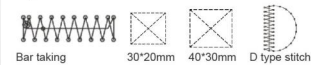

JK1900ACS
For cap circle

JK1900BSK
For button attaching

JK1900ASS 电子套结机

Electric bar tacking machine

JK1900ASS	DPx5 14#	1	1	30x20	★	370W 1420rpm 220-380	★	17	3000	800x650x500	60/65
JK1900AHS	DPx5 18#	1	1	30x20	★	370W 1400rpm 220-380	★	17	3000	800x650x500	60/65
JK1900BSK	DPx5 11#	1	1	30x20	★	370W 1420rpm 220-380	★	17	3000	800x650x500	60/65



JK430D-ABN
No bird-nest under the cloth

JK430D-BL
For belt loop attaching

JK430D-4030
Bar tacking area 40x30mm



JK430D-MO
For circle eye (standard dia 17mm)

JK-430D-SOT
with lining attaching device

JK430D-ZSOT
with auto feeding lining attaching device

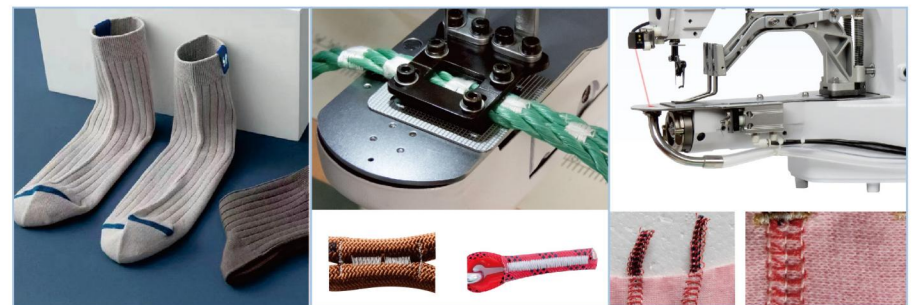

JK430E-DZB
For trademark folding and attaching

JK430D-YW
For fishing net

JK430D-QD
Cut thread end and bar tacking



The shape of pattern can be shown on the screen when the user edits the pattern, which provides convenience for user to confirm and modify the pattern data. The electronic thread holder is controlled by the solenoid. User can change the upper thread tension via the operating board at will, to improve the accuracy for adjusting the upper thread.



Sliding clamp device(CH)



Flip flop device(FZ)

JK210E 电子花样机

Electrical pattern program machine, sewing area: 130x60mm, pneumatic lifting foot

Icon	Icon	Icon	Icon	Icon	Icon	Icon	Icon	Icon	Icon
Model	DPx17(18#)	130x60	0.05-12.7	★	★	25	2800	880x510x680	100/120
JK210E(1306)	DPx17(18#)	130x60	0.05-12.7	★	★	25	2800	880x510x680	100/120
JK210E(2210)	DPx17(18#)	220x100	0.05-12.7	★	★	25	2800	880x510x680	100/120
JK210E(3020)	DPx17(18#)	300x200	0.05-12.7	★	★	25	2800	1250x1100x1350	190/210



This machine use programmable presser foot. Equipped with the disconnection holding device, strengthen the needle penetration. Pattern edit quick and easy. Mainly suit for all kinds of men and women apparel industry, denim, knits, lingerie, luggage, footwear and other purposes.

- JK1010AS 100x100mm
- JK1310AS 130x100mm
- JK2210AS 220x100mm
- JK3020AS 300x200mm
- JK6040AS 600x400mm



Hat shape presser foot(MY)



Template changeable device(HM)

JK3020AS 电子花样机

Electric pattern sewing machine, working area is 30X20cm

Icon	Icon	Icon	Icon	Icon	Icon	Icon	Icon	Icon	Icon
Model	DPx17(18#)	130x100	0.05-12.7	★	★	25	2700	1220x840x1320	147/195
JK1310AS	DPx17(18#)	130x100	0.05-12.7	★	★	25	2700	1220x840x1320	147/195
JK2210AS	DPx17(18#)	220x100	0.05-12.7	★	★	30	2700	1220x840x1320	139/183
JK3020AS	DPx17(18#)	300x200	0.05-12.7	★	★	30	2700	1220x1080x1320	219/278



This machine is widely used for handbag, suitcase, computer bag, golf bag, shoes, clothing, jeans, sports product, cellphone covers, belts, magic tape, reusable bags, toys, pet products, zipper, leather products. etc. With strengthen needle penetration and standard thread broken sensor. Patterns edit quick and easy.



JK-M3020H 电子花样机

Electronic pattern sewing machine

Icon	Icon	Icon	Icon	Icon	Icon	Icon	Icon	Icon	Icon
Model	DPx17	300x200	0.5-12.7	★	★	20	3000	1220x820x1320	160/200
JK-M3020H	DPx17	300x200	0.5-12.7	★	★	20	3000	1220x820x1320	160/200
JK-M4030H	DPx17	400x300	0.5-12.7	★	★	20	3000	1520x1220x1320	180/220
JK-M5030H	DPx17	500x300	0.5-12.7	★	★	20	3000	1520x1220x1320	180/220



This machine is widely used for handbag, suitcase, computer bag, golf bag, shoes, clothing, jeans, sports product, cellphone covers, belts, magic tape, reusable bags, toys, pet products, zipper, leather products. etc. With strengthen needle penetration and standard thread broken sensor. Patterns edit quick and easy.



JK311-TD-S 电子花样机 (硬币口袋)

Full automatic pocket setter machine for coin pocket

Icon	Icon	Icon	Icon	Icon	Icon	Icon	Icon	Icon	Icon
Model	DPx17(18#)	130x100	0.05-12.7	★	★	25	2700	1240x940x1350	147/195
JK1311-TD-S	DPx17(18#)	130x100	0.05-12.7	★	★	25	2700	1240x940x1350	147/195

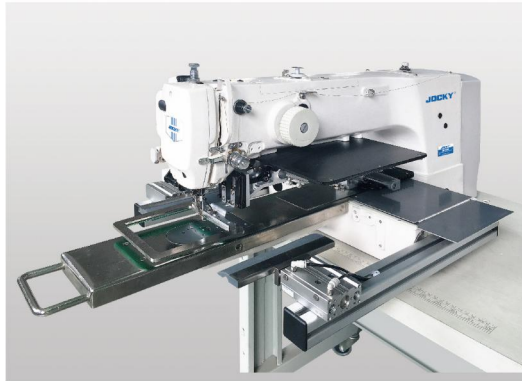

Small cylinder long arm design, especially suitable for jeans leg decoration sewing or hole repair and other special purposes. Mainly used for jeans leg decoration sewing or hole repair and other special purposes, can also be used for casual pants, snow boots, golf bags and other patterns and trademarks sewing.



JK210E-BK1010 小嘴花样补裤机

Cylinder bed electronic pattern sewing machine (for pants repair)

Model	DP	Table Size	Needle	Star	Star	Presser	S.p.m.	Table Size	NW/GW
JK210E-BK1010	DPx17(18#)	100x100	0.05-12.7	★	★	25	2800	880x510x680	100/120
JK221E-BK2022	DPx17(18#)	200x220	0.05-12.7	★	★	25	2800	1250x1100x1350	210/190



It can process 2500 pieces leather label in 8 hours, and the production efficiency is 15 times higher than traditional processing. The start and end seam points are in the middle and upper positions of the label. Through professional press foot and lable clamp, which can sew a variety of labels accurately. Suitable for sewing leather tags, labels or warning signs of jeans, bags, clothing etc.



JK-1310TB 贴标花样机

Electronic pattern sewing machine (for label attaching)

Model	DP	Table Size	Needle	Air pressure	Presser	Power	S.p.m.	Table Size	NW/GW
JK1310AS	DPx17(18#)	130x100	0.1-12.7	0.5Mpa 1.8L/min	25	550W 220V 50/60Hz	2800	1140x720x1300	150/195



This machine is mainly used for reinforcing the seams on pillows and chair cushions. It uses a dual-drive needle bar that automatically lifts the needle after sewing is completed.

JK1254 Lifting height 90mm, Y length 240mm
 JK1254A Lifting height 115mm, Y length 300mm
 JK2254 Lifting height 180mm, Y length 450mm
 JK2254A Lifting height 250mm, Y length 680mm



JK2254

JK1254 电脑椅垫花样机

Electronic pattern sewing machine (for cushion)

Model	DP	Star	Star	Presser	S.p.m.	Table Size	NW/GW
JK1254	DPx17 18#	★	★	90	2200	800x380x800	65/70
JK2254	DPx17 18#	★	★	180	1500	1250x1000x1500	200/300



Suitable for curved sewing of hat brims and other products. X bobbin of curved sewing secure curved shape of the products. Adjustable jig is suitable for fabric of different specification. One person can operate three machines, highly increase working efficiency.

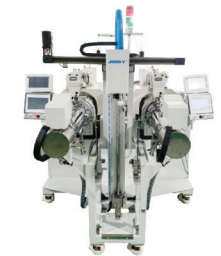

JK2116-2

JK2116-1AF 自动弯眉单拼机

Automatic curved visor sewing machine (for cap brim)

Model	DP	Table Size	Needle	Productivity	Air pressure	S.p.m.	Table Size	NW/GW
JK2116-AF	DPx5 DPX17 12-16#	210x160	0.05-12.7	1300pcs/10hours	0.5Mpa, 1.8L/min	2200	1910x910x1600	360/405
JK2116-2	DPx5 DPX17 12-16#	210x160	0.05-12.7	2600pcs/10hours	0.5Mpa, 1.8L/min	1500	1580x1400x1660	560/630



JK2290A-SR-7 电脑曲折缝 (自动剪线)
Computerized zigzag sewing machine (auto trimmer)



JK2284C-7P 电脑小嘴式曲折缝 (自动剪线)
Computerized cylinder bed zigzag sewing machine (auto trimmer, auto lifting foot)



JK5530-S4 电脑厚料曲折缝 (步进剪线)
Computerized heavy duty zigzag sewing machine (step motor auto trimmer)



JK5530-1SE-D4 直驱厚料曲折缝 (单步进)
Direct drive heavy duty zigzag sewing machine (auto trimmer)



JK2284E-7P 电脑曲折缝 (自动剪线)
Computerized zigzag sewing machine (auto trimmer, auto lifting foot)



JK2284E-2-7P 电脑双针式曲折缝 (自动剪线)
Computerized double needle zigzag sewing machine (auto trimmer, auto lifting foot)



JK5530-D4 电脑厚料曲折缝 (自动剪线)
Computerized heavy duty zigzag sewing machine (auto trimmer)



JK5530-1SE-D 直驱厚料曲折缝 (单步进)
Direct drive heavy duty zigzag sewing machine (1 step motor, 190 patterns)



JK2284E 直驱曲折缝
Direct drive zigzag sewing machine



JK2284 曲折缝
Zigzag sewing machine



JK5530D 直驱厚料曲折缝
Direct drive heavy duty zigzag sewing machine



JK5530-2SE-D 直驱厚料曲折缝 (双步进)
Direct drive heavy duty zigzag sewing machine (2 step motor, 210 patterns)

	DPx5	5	4	0-9	5.5-10	5000	770x380x710	NW/GW kg
JK2290A-SR-7	DPx5	5	4	0-9	5.5-10	5000	770x380x710	60/72
JK2284C-7P	DPx5	5	4	0-9	5.5-10	4500	715x365x620	52/55
JK2284E-2-7P	DPx5	5	4	0-9	5.5-10	4500	715x365x620	52/55
JK2284E-7P	DPx5	5	4	0-9	5.5-10	4500	715x365x620	52/55
JK2284E	DPx5	5	4	0-9	5.5-10	4500	680x350x620	47/50
JK2284	DPx5	5	4	0-9	5.5-10	4500	680x350x620	39/47

	DPx5	5	5	0-10	8/13	550	2500	640x250x540	NW/GW kg	
JK5530-S4	DPx5	5	5	0-10	8/13	★	550	2500	640x250x540	40/45
JK5530-D4	DPx5	5	5	0-10	8/13	★	550	2500	640x250x540	40/45
JK5530-1SE-D4	DPx5	5	5	0-12	8/13	★	550	2500	640x250x540	42/48
JK5530-1SE-D	DPx5	5	5	0-12	8/13	★	550	2500	640x250x540	38/44
JK5530-2SE-D	DPx5	5	5	0-12	8/13	★	550	2000	680x270x580	42/47
JK5530D	DPx5	5	5	0-10	8/13	★	550	2500	540x250x540	31/35



JK20U2SE-D 双步进电脑花样曲折缝
Direct drive zigzag machine
(240 patterns, double step motor)



JK20U1SE-D 单步进电脑花样曲折缝
Direct drive zigzag sewing machine
(190 patterns, single step motor)



JK20U2S-D 双步进电脑花样曲折缝
Computerized zigzag sewing machine
(240 patterns, double step motor)



JK20U1S-D 单步进电脑花样曲折缝
Direct drive zigzag sewing machine
(190 patterns, single step motor)



JK20U43DD 直驱曲折缝
Direct drive zigzag sewing machine



JK20U93DD 直驱曲折缝
Direct drive zigzag sewing machine

Icon	Icon	Icon	Icon	Icon	Icon	Icon
Model	DPx5 (10-14#)	mm	mm	S.p.m.	mm	NW/GW kg
JK20U1S-D	DPx5 (10-14#)	5	6-12	2000	580x250x510	21/26
JK20U1SE-D	DPx5 (10-14#)	5	6-12	2000	580x250x510	21/26
JK20U2S-D	DPx5 (10-14#)	5	6-12	1800	580x250x510	23/28
JK20U2SE-D	DPx5 (19-23#)	11	6-12	1800	580x250x510	23/28
JK20U43DD	DPx5 (10-14#)	12	6-12	2000	580x250x480	23/28
JK20U93DD	DPx5 (10-14#)	12	6-12	2000	580x250x480	23/28



JK2530-D4 自动剪线同步厚料曲折缝
Computerized up and bottom feed zigzag sewing machine (auto trimmer)



JK1530-D4 自动剪线厚料曲折缝
Computerized zigzag sewing machine (auto trimmer)



JK1530D 直驱曲折缝
Direct drive zigzag sewing machine



JK2153MX-DD 直驱小嘴同步曲折缝
Direct drive walking foot zigzag sewing machine for binding edge



JK2526 曲臂式曲折缝
Feed off the arm zigzag sewing machine



JK2552 立柱式曲折缝
Post bed zigzag sewing machine

Icon	Icon	Icon	Icon	Icon	Icon	Icon
Model	DPx5 (10-14#)	mm	mm	S.p.m.	mm	NW/GW kg
JK1530-D4	DPx5 (10-14#)	5	5.5-10	4500	630x250x550	34/38
JK2530-D4	DPx5 (10-14#)	8	5.5-10	4500	630x250x550	34/38
JK1530D	DPx5 (10-14#)	11	5.5-10	4000	630x250x550	34/38
JK2153MX-DD	DPx5 (19-23#)	3	6-13	3000	690x325x610	52/56
JK2526	DPx5 (10-14#)	11	5.5-10	4000	710x500x400	35/40
JK2552	DPx5 (19-23#)	3	6-13	3000	650x780x260	35/40

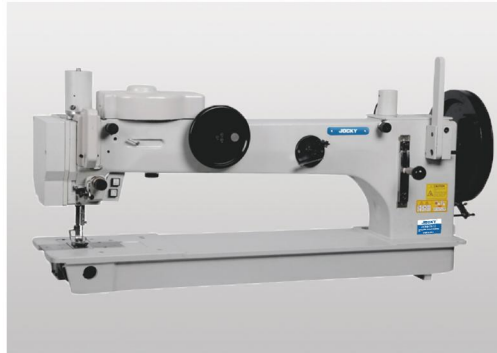

This machine is suitable for sewing extra heavy duty products, such as canvas, tents, parachutes, camps, etc. Pneumatic foot lifter and back reverse, extra large shuttle hook, for heavy thread.

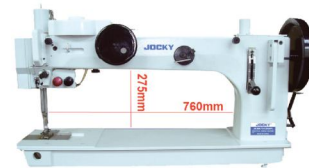

JK366-76-12HAPL

JK366-76-12 曲折缝纫机

Extra heavy zigzag sewing machine

	DPx3 25#	12	2	★	20	760X175	800	1250x500x710	NW/GW Kg
JK366-76-12	DPx3 25#	12	2	★	20	760X175	800	1250x500x820	243/207
JK366-76-12PL	DPx3 25#	12	2	★	20	760X175	800	1250x500x710	223/187
JK366-76-12HAPL	DPx3 25#	12	2	★	20	760X275	800	1250x580x820	253/217



This machine is suitable for, Suitable for sewing thick materials, especially sports and leather products, such as bags, shoes, hat, sofa, tents, golf gloves, diving suits etc. working area is 780x100mm

JK2150L-78-2 1 step 2 point
JK2150L-78-3 2 step 3 point
JK2150L-78-4 3 step 4 point



JK2150L-78-2 长臂曲折缝

Extra heavy long arm zigzag sewing machine

	DPx17 #14-#22	4.5	★	★	17	800	1120x270x620	NW/GW Kg
JK2150L-78-2	DPx17 #14-#22	4.5	★	★	17	800	1120x270x620	70/95
JK2150L-78-3	DPx17 #14-#22	4.5	★	★	17	800	1120x270x620	70/95
JK2150L-78-4	DPx17 #14-#22	4.5	★	★	17	800	1120x270x620	70/95



JK5880-1S-2N 单步进直驱链式缝纫机 (双针)

Direct drive chainstitch sewing machine, with stepper motor

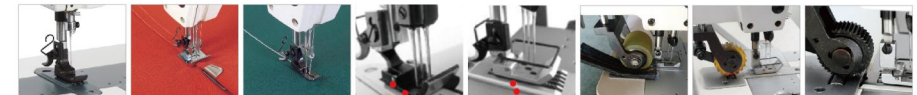

Edge cutter JK390-2N(P) JK390-2N(T) Front/back 3 needle Diagonal 3 needle Flat rubber roller Gear rubber roller Gear metal roller

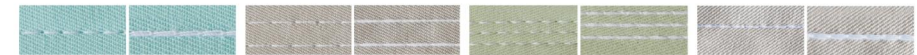

1-needle chainstitch Parallel 2-needle chainstitch 3-needle chainstitch Tandem 2-needle chainstitch



JK5980-1S-2N JK5800E-2N JK390DD-2N JK390-2N

	TVx7(9-21#)	4	★	2	★	★	5.5/10	4500	625x250x555	33/41
JK390 series	TVx7(9-21#)	4	★	2	★	★	5.5/10	4500	625x250x555	33/41
JK5880/5980 series	TVx7(9-21#)	4	★	3	★	★	5.5/10	4500	625x250x555	33/41
JK5800E series	TVx7(9-21#)	4	★	3	★	★	5.5/10	4500	625x250x555	33/41



The designation of touch screen makes many process finished by touching screen, such as changing the length of pinpoint and stitch length, operating half stitch button, auto-adjustable positive and negative pin-point, setting stitches and so on, stored one thousand of stitches that you can select one of them through the touch screen, auto-trimming function or manual trimming function, presser lifted pneumatically or by right knee.



JK-H785 电脑珠边机

Computerized hand stitch sewing machine

			Thread length (mm)		Air pressure (mm)		S.p.m.		mm		NW/GW Kg
JK-H785	780C	16#18#20#23#	10 120	37	Satm	8-10	500	1280x960x860		180/220	



An independent thread tensioner releases the thread for easy thread pulling. The cylinder arm provides superior garment movement. Use flat knife to trim the thread, while the bobbin thread is clamped. The trimmed thread is long, no need dense stitch or back reverse stitch when starting stitches. Especially for tacking and basting of jackets, overcoats, shoulder pads, etc



JK333D 筒式复衬机

Computerized cylinder bed tacking and basting machine

			Thread length (mm)		Air pressure (mm)		S.p.m.		mm		NW/GW Kg
JK333D	MTX190	15	35	19	220V 50/60HZ	1,500	650x280x590		45/52		



This machine has reasonable framework, steady operation, low noise, beautiful stitch, easy operation and durable features. It is suitable for the decorative sewing of suits, men's and women's leisure wear, overcoat, trousers and shirts.



JK388DD 直驱珠边机

Direct drive hand stitch sewing machine

			Thread length (mm)		Air pressure (mm)		S.p.m.		mm		NW/GW Kg
JK388DD	DPx5	11-14#	5	3-10	1400	590x230x550		28/36			



An independent thread tensioner releases the thread for easy thread pulling, excellent handling through large table top. Use flat knife to trim the thread, while the bobbin thread is clamped. The trimmed thread end is long, no need dense stitch or back reverse stitch when starting stitches. Especially for tacking and basting of jackets, overcoats, shoulder pads, etc.

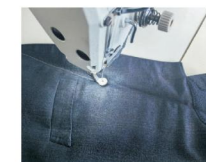

JK1243N 平面复衬机

Computerized flat bed tacking and basting machine

			Thread length (mm)		Air pressure (mm)		S.p.m.		mm		NW/GW Kg
JK1243N	DBX1	6	30	15	220V 50/60HZ	1,500	680x270x550		46/45		



JK9688XH-PF/ECV-DPC-T-BD

全自动全供油高速埋夹机

Automatic feed off the arm machine(full oil lubrication)

The highest working speed feed off the arm machine so far. Automatic oil supply system with circulating oil filtering and cooling. Oil is supplied to the upper and lower shafts at the same time, so that the lubrication of the parts is guaranteed.



JK-J9588XH-MPF/ECV

全自动埋夹机

Automatic feed off the arm machine

Makes the operation flexible anefficient. Eliminate wrinkling, needle jumping dislocation etc. Suitable for burying clipback wave, outside seam, inside seam, anpressing seam of back cross seam of jeanscasual pants, work clothes and jeans.



Model detail:

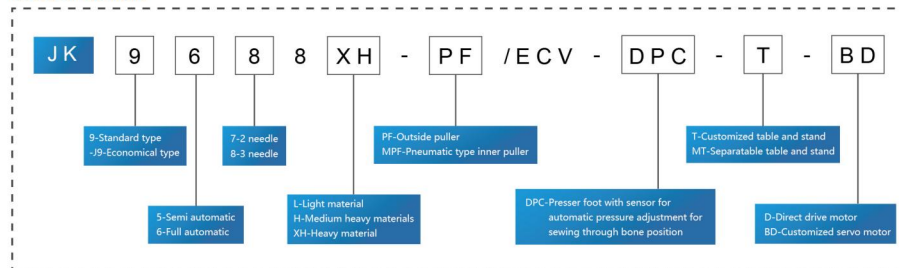

JK9688 series	TVx64 14#	2/3	6	1/4, 9/32, 5/16, 3/8, 1/2	9	5500	1000x750x1100	115/145
JK-J9588 series	TVx64 14#	1/3	6	1/4, 9/32, 5/16, 3/8, 1/2	9	5500	1000x750x1100	115/145



JK927DD-2PL 直驱埋夹机

Direct drive feed off the arm sewing machine



JK927DD-PS 直驱埋夹机

Direct drive feed off the arm sewing machine



JK928HDD-2PL 直驱埋夹机

Direct drive feed off the arm sewing machine



JK928LDD 直驱埋夹机

Direct drive feed off the arm sewing machine

					Puller type	⚙️ S.p.m.	📏 mm	⚖️ NW/GW Kg
JK927DD-2PL	TVx64 14#	2	3-3.5	1/4, 1/8, 3/16, 7/32	Built-in double puller	3500	575x520x485	55/58
JK927DD-PS	TVx64 14#	2	3-3.5	1/4, 1/8, 3/16, 7/32	External	3500	575x520x485	55/58
JK928LDD	TVx518#	3	1.2-5.2	1/4, 9/32, 5/16, 3/8, 1/2	-	3500	575x520x485	55/58
JK928HDD-2PL	TVx518#	3	1.2-5.2	1/4, 9/32, 5/16, 3/8, 1/2	Built-in double puller	3500	575x520x485	55/58



JK364-QBD3 前后差动电脑暗缝机

Direct drive blind stitch sewing machine, with auto trimmer, front/back differential feed

With differential feed dog, effectively keeping the movement of fabric in synchronization, and the stitch length in good condition. With adjustable press fitting device, suitable to do various material in different thickness.



JK600-QD3 自动剪线暗缝机

Direct drive blind stitch sewing machine, with auto trimmer

Widely used for hemming cuff, pant, shirt, glove, sock, front and back of western suit etc, and suit various materials, such as cotton, wool, chemical fiber etc.



JK600DD

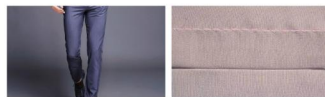

JK370DD-T 直驱裤耳暗缝机

Direct drive blind stitch machine, with auto ironing device

With advanced cloth feeding device, the machine can automatically carry out smooth and gentle feeding, with automatic ironing (electric heating) device, which can directly iron the semi-finished trouser ear.

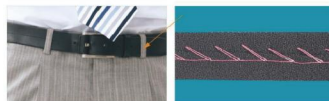

JK140 筒式暗缝机

Tubular blind stitch machine

For adoption of blind stitch mode, the sewn stitch is invisible from the surface of fabric, which maintain the clothes much neater and more elegant. The equipped adjustable rolling bracket fixes the elastic cotton fabric with different calibers, which makes it easy to be operated. Suit for socks, gloves, cuffs of sleeves, etc, such small caliber things blindstitch.



JK1430 潜水衣暗缝机

Blind stitch sewing machine, for diving suits

Equipped adjustable roller bracket to fix the elastic cotton fabric with different calibers, which makes it easy to be operated.

Its special synchronized feeding device makes the sewing faster and more reliable. Suit for blind stitch the clothes in cotton needle-weaving and chemical materials, especially for the rubber diving suits, waterproof suits and surfing suits.

JK1430 Single thread
JK2430 Double thread



JK500 暗缝机

Blind stitch sewing machine

For adoption of blind stitch mode, the sewn stitch is invisible from the surface of fabric, which maintain the clothes much neater and more elegant, widely used for hemming cuff, pant, shirt, glove, sock, front and back of western suit, etc. Suit various material such as cotton, wool, chemical fiber, etc.





JK591DES 步进电脑罗拉车
Computerized step motor post bed sewing machine



JK591DE 单针电脑罗拉车
Computerized post bed sewing machine (single needle)



JK9910 单针罗拉车
Single needle post bed sewing machine



JK810DW 直驱假发高头车
Direct drive single needle post bed sewing machine (for wigs)



JK592XZ-30 双针小嘴电脑罗拉车
Computerized small size post bed sewing machine (double needle, post height 30cm)



JK1591N-TK 针送料电脑罗拉车(带斩刀)
Needle feeding computerized post bed sewing machine (single needle, with tape cutter)



JK8360 综合送料旋转高柱车
Post bed compound feed arm sewing machine



JK8365 综合送料高柱车
Post bed compound feed arm sewing machine

Model	Needle	Stitch	Presser	Table	Max. Sewing Width	Max. Sewing Length	Max. Sewing Thickness	Max. Sewing Weight
			mm	mm	(mm)	S.p.m.	mm	NW/GW Kg
JK591DES	DPx5x(11-22#)	1	38	7	7-14	2500	740x365x700	61/68
JK591DE	DPx5x(11-22#)	2	41	4	7-14	2500	740x365x700	61/68
JK592XZ-30	DPx5 16-18#	2	36	5	7-11	2500	740x365x700	61/68
JK159N-TK	DPx5x(11-22#)	1	38	7	7-14	2500	740x365x700	61/68

Model	Needle	Stitch	Presser	Table	Max. Sewing Width	Max. Sewing Length	Max. Sewing Thickness	Max. Sewing Weight
			mm	mm	(mm)	S.p.m.	mm	NW/GW Kg
JK9910DD/JK9910	DPx5 11-20#	1	38	7	8-15	2500	670x330x680	49/56
JK810DW	DPx5 16-18#	1	36	5	7-11	2500	650x260x570	31/35
JK8360	DYx17	1	36	6.0	20	1500	1250x800x400	100/120
JK8365	DPx17	1	36	6.0	15	1600	670x365x915	55/60



JK669-121226 综合送料筒形缝纫机
Cylinder bed compound feed sewing machine



JK1342-7D 综合送料筒形缝纫机
(auto trimmer)
Cylinder bed compound feed sewing machine



JK2628U-DD 直驱综合送料筒形缝纫机
Direct drive cylinder bed compound feed sewing machine



JK441 综合送料筒形缝纫机
Cylinder bed compound feed sewing machine



JK335ALD 直驱综合送料筒形缝纫机
Direct drive cylinder bed compound feed sewing machine



JK8BD 直驱综合送料筒形缝纫机
Direct drive cylinder bed compound feed sewing machine



JK1341 综合送料筒形缝纫机
Cylinder bed compound feed sewing machine



JK1341L 长臂筒形缝纫机
Long arm cylinder bed compound feed sewing machine
(arm length 1000/1300mm)

Icon	Icon	Icon	Icon	Icon	Icon	Icon	Icon	Icon
Model	DPX	mm	mm	V/Hz	W	S.p.m.	mm	NW/GW Kg
JK669-121226	DPX35 90-180	9	20	200-240V,50/60HZ	750W	3000	655x370x550	50/56
JK1342-7D	DPX17 23#	8	9/16	200-240V,50/60HZ	750W	2500	730x330x720	45/50
JK335ALD	DPX17	5.5	15	200-240V,50/60HZ	750W	2000	675x275x470	25/32
JK8BD	DPX17	5.5	13	200-240V,50/60HZ	750W	2000	675x275x500	25/32

Icon	Icon	Icon	Icon	Icon	Icon	Icon	Icon	Icon
Model	DPX	mm	mm	V/Hz	W	S.p.m.	mm	NW/GW Kg
JK2628U-DD	DPX17	11	15	2000	675x275x500	25/32		
JK441	DPX17	5.5	13	2000	790x455x580	55/59		
JK1341	DPX17 23#	8	9/16	2500	735x340x640	38/48		
JK1341L	DPX17 23#	8	9/16	2500	1300x340x640	58/68		



JK-155D 毛衫埋夹机
Sweater seaming machine



JK-988D 毛衫埋夹机
Sweater seaming machine



JK800-1 中底缝合机 (单线)
High capacity string lasting heavy duty machine (single thread)



JK800-2 中底缝合机 (双线)
High capacity string lasting heavy duty machine (double thread)



JK-600BA 直驱自动剪线拉邦机
Direct drive high capacity string lasting heavy duty machine (auto trimmer)



JK-600BD 直驱拉邦机
Direct drive high capacity string lasting heavy duty machine



JK2610-5DD 直驱中薄料裘皮机
Direct drive fur sewing machine (for heavy material)



JK2610-TD2 毛绒玩具款求皮机
Direct drive fur sewing machine (for plush toys)

	Icon	Model	Needles	Stitch Length (mm)	Stitch Width (mm)	Stitch Density (mm)	Stitch Type	Stitch Pattern	S.p.m.	Table Size (mm)	NW/GW (Kg)	
JK-155D	Icon	BBX155 120/19	2	1-7	33.6	3-5	★	★	★	3500	475x430x410	34/41.5
JK-988D	Icon	BBX155 120/19	2	1-7	33.6	3-5	★	★	★	3500	475x430x410	34/41.6
JK-600BA	Icon	DBX5 140/22	1	3-8	33.6	3-7	-	★	★	2500	565x510x440	36.5/47.5
JK-600BD	Icon	DBX5 140/22	1	3-8	33.6	3-7	-	★	★	2500	565x510x440	32/37

	Icon	Model	Needles	Stitch Length (mm)	Stitch Width (mm)	Stitch Density (mm)	Stitch Type	Stitch Pattern	S.p.m.	Table Size (mm)	NW/GW (Kg)	
JK800-1	Icon	DPX35LR 23/160	1	3-6	32.4	3-10	-	★	★	2800	495x400x390	25.5/29
JK800-2	Icon	DBX1 14/90	2	2-4	28	2-4	-	★	-	2800	495x400x390	24.6/28.5
JK2610-5DD	Icon	DBX1 75/11	1	0.9-3	25.5	2.5	-	★	-	2500	420x420x360	25.5/30.5
JK2610-TD2	Icon	DBX1 14/90	1	0.9-3	29	2.5	-	★	-	2500	530x340x365	34.5/44.5



JK204D-1 电脑双针摩卡车
Double needle mocassin machine

Different patterns are realized by needle rod rotation technology, including T-shaped, X-shaped, mouth-shaped and so on. 293 decorative patterns, capable of using very thick wires (1500cx3, V415, V452, T ≤ 500) or 1.4mm hollow line flat or decorative line)



JK204D-1G
High bed type

JK204D-1	DYx3 27#	5.5-12	0-10	10	320x185	350	1310x700x1300	165/195



JK168 双线内线机
Double inner line machine

Light rocker, easy to operate, oiled system to protect the oxford, divided rotating structure power turn-off manually and stop when gripping to protect machine, presser is controlled by computer, the rev can be set according to the operator. Suit for sneakers, casual shoes and other special materials.



JK168	Cpx5	26/11	1.5-6	3-13	500W/380V	2000	1150x600x1290	110/139



JK-296 自动上胶分边锤平机
Auto-cementing separating sides and pounding machine

This machine can improve the work efficiency, reduce working procedure, and don't damage the material. Suit for integrative task of multi-working procedure of the automatic edge division cementing and pounding of joint of the material of PVC, PU leather, nature leather, synthetic leather and cloth material for shoes upper, cases, bag, cell phone bag and all kinds of leather products.



JK-298-B 电脑上胶折边机
Auto hot-cement edge folding machine

Suit for material of PVC, PU leather, nature leather, artificial leather and cloth for shoes, leather bag, wallet and cell-phone cover which are made of leather, it can automatically gelatinize with hot-cement, folding width can be adjusted to 3-8mm, rotating button adjusts the temperature, flow quantity of the thermoelement with easy regulating and accurate indicating, light sensitive resistance controls the discharge stably and accurately.



JK-296	650W/220V	1200x550x1200	113/150
JK-298-B2	400W/220V	1250x610x1140	105/147



JK-B38 贝型饰边缝纫机

Shell stitch sewing machine

It can produce any one of the three different combinations of finished stitches (1/4/8 stitches). Suitable for suits, sweater, coat, fashionable dress, robe, blanket, cushion, towel etc.

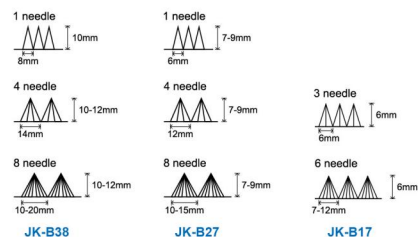

JK1721PK 对丝机

Picoting sewing machine, with cutter and puller

This machine is used for embroidering women's skirts, shirts, handkerchiefs, ties, tablecloths, and sheets.

JK1721 Basic type
JK1721P With puller
JK1721PK With puller and knife



JK1668 抽纱机

Fagoting sewing machine

It can be part of the fabric cross-thread removal, to ensure the best results out of function of the thread.



JK1250G 打折机

Chainstitch pleating machine

Equipped with pleating device, suitable for children's clothing, skirts, women's clothing, bedspreads and curtains.

JK1250G Single pleating
(1/2/3 stitches for one pleating)
JK1250G-2 Adjustable pleating (4 types)



JK1260G 多功能打折机

Multi function chainstitch pleating machine

Can sew different styles of pleating stitches by changing the cam (total 14 cams). Easy operate and maintain. Suitable for all kinds of pleating processes.

JK1260G Single needle lockstitch
JK1260G-2 Double needle chainstitch

01		08	
02		09	
03		10	
04		11	
05		12	
06		13	
07		14	



JK1208D-2 电脑亮片机

Electronic control sequin machine

The sequin feeding mechanism is controlled by the program and can be freely selected to switch between 1-12 needle sequin feeding patterns.

JK1208D Sequin sewing
JK1208DA Sequin compensating sewing
JK1208D-2 2-pieces crossing sequin sewing
JK1209D Chainstitch sequin sewing

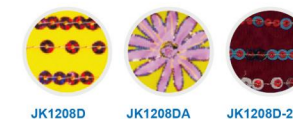



JK-BS1-2 毛毯锁边机

Blanket overlock sewing machine

Suitable for cotton blankets, woolen blankets, baby blankets and the other common cloths. It is a single thread lockstitch with neat edge.



TM7001 单头钉标机

Pneumatic auto feeding tagging machine, for single tag
Feed the tags automatically, tagging speed can reach 1piece/second. The tag width range is 10mm~80mm. Suitable for tagging tags on T-shirts (single tag), toys and other products.

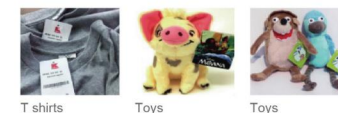

JK-GS72-3 双线链式手套机

1 needle 2 thread chain stitch glove sewing machine

The whole machine adopts a fully enclosed double gear oil pump for oil feeding automatically. The effective head space is 125x80mm.



JK-GS72-4
with side cutter



JK-GS72-3DD
with direct drive motor



TM2001 标签打印钉标机

Automatic printing and tagging machine

The machine employs PLC control and pneumatic assistance to streamline the labeling process for workers. Suitable for thinner textiles, the fine needles and adhesive cause no damage to fabrics. Ideal for towels, plush toys, underwear, slippers, and more.



JK401 单针链式手套机

Single needle chain stitch glove sewing machine

Adopts cam take-up thread, looper hook thread, upper-feeding mechanism, can do 401 double chain stitch. Adopts column structure of curved needle, can sewing small items better with goods stitch. No need bobbin winding device. Suitable for sewing gloves and other small tubular materials.



JK401DD
Direct drive type



TM43 钉线机

Thread attaching machine(3needle 4 thread)

This machine can greatly reduce the labor intensity of the operator and increase the binding speed. Suitable for fixing paper labels on jeans, underwear, gloves, clothing, dolls, socks and other textile products.

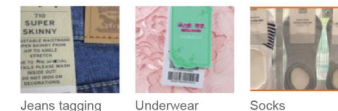

Model	Needle	Presser	Presser foot	Presser foot	Presser foot	Presser foot	Presser foot	Presser foot	NW/GW Kg
JK-BS1-2	DMx5	1.1-10	10	-	-	7	1000	310x180x320	12/13.5
JK-GS72-3	DCx1	3.5	3.2	-	-	5	3500	385x220x380	12/13.5
JK401	DPx17	6.0	-	443	47	15	1000	530x250x430	16/18

Model	Needle	Tagging thickness	Needle style	Air pressure	Power	Presser foot	NW/GW Kg
TM7001	TN3709	5-30mm	Fine/Thin	0.4-0.8Mpa	220V/50HZ	550x320x520	25/30
TM2001	TN3.7	5-15mm	Fine/Thin	0.4-0.8Mpa	220V/50HZ	850x650x130	82/95
TM43	TQx7	5-20mm	Fine/Thin	0.4-0.8Mpa	220V/50HZ	750x650x1150	75/85

GK95-1A

单针双线高速封包机
High speed bag sewing machine
1 needle 2 thread chainstitch



GK95-4A

双针四线高速封包机
High speed bag sewing machine
2 needle 4 thread chainstitch



GK26-1A

单针双线封包机
Bag closer machine



GK35-6AZ (GK35-6A + GKS-ZL + GK4900 + GKS-2)

缝包折边输送机组
Automatic folding and bag closing sewing machine
(Bag closing + Stand + Folding device + Feeding device)



GK35-1

双线封包机
2 thread flat bed bag sewing machine



GK35-2S

双针四线封包机
2 needle 4 thread flat bed bag sewing machine



GK35-2C

筒式双线封包机
2 thread cylinder bed bag sewing machine



GK35-6AX (GK35-6A + GKS-ZL + CM4900-3 + GKS-2)

缝包修剪输送机组
Automatic folding and bag closing sewing machine
(Bag closing + Stand + Folding device + Feeding device)



GK9-520

手提封包机
Portable bag closer machine



GK9-550

单针双线手提封包机
Single needle double thread bag closer machine



GK9-660

双针双线手提封包机
Double needle double thread bag closer machine



GK35-6A
缝包机
Bag closer machine



GK4900
缝包折边机
Folding device for bag closer machine



CM4900-3
缝包修剪机
Trimming device for bag closer machine



GKS-ZL
缝包机立柱
Stand for bag closer machine





JK-ES5 缝绣一体机
Household sewing&embroidery machine,
100x235mm



JK-ES6 缝绣一体机
Household sewing&embroidery machine,
200x280mm



JK-MC1201 迷你帽绣机
Mini cap embroidery machine
300x200mm

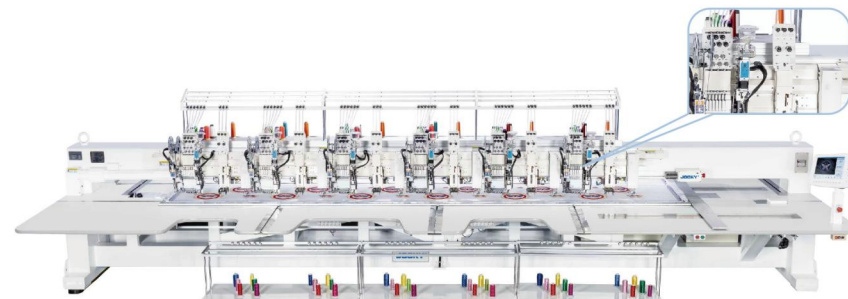

JK-FPDMJ Series

混合盘带绣花机
Mixed tapping embroidery machine

- JK-FPDMJ604 6 chenille 6 needle 4 head
- JK-FPDMJ604 6 chenille 6 needle 4 head
- JK-FPDMJ606 6 chenille 6 needle 6 head
- JK-FPDMJ606 6 chenille 6 needle 6 head
- JK-FPDMJ608 6 chenille 6 needle 8 head
- JK-FPDMJ608 6 chenille 6 needle 8 head



JK-BC1501 单头帽绣机
Single head cap embroidery machine
510x400mm



JK-BC1502 双头帽绣机
Double head cap embroidery machine
450x400mm



JK-BC1504 四头帽绣机
Four head cap embroidery machine
400x400mm

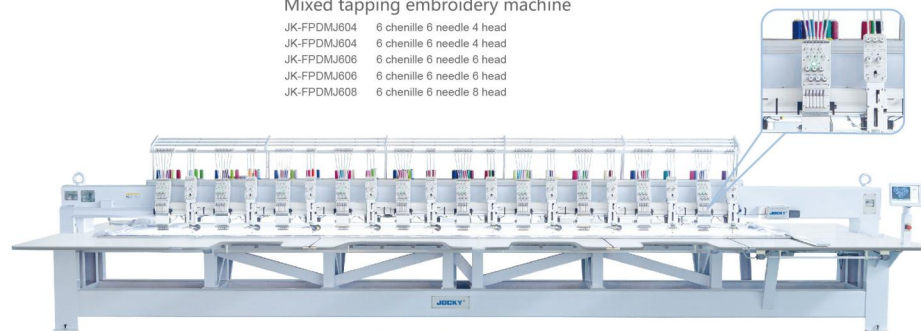

JK-FPD Series

混合毛巾绣花机
Mixed towel embroidery machine

- JK-FPD-6-606 6 chenille 6 needle 6 head
- JK-FPD-6-906 6 chenille 9 needle 6 head
- JK-FPD-8-608 6 chenille 6 needle 8 head
- JK-FPD-8-908 6 chenille 9 needle 8 head
- JK-FPD-10-610 6 chenille 6 needle 10 head



Optional: laser device



JK-KC1501 单头帽绣机
Cap embroidery machine
360*240mm

JK-FG Series

高速多头绣花机
High speed embroidery machine

- JK-FG-904 9 needle 4 head
- JK-FG-906 9 needle 6 head
- JK-FG-908 9 needle 8 head
- JK-FG-910 9 needle 10 head
- JK-FG-912 9 needle 12 head

Optional



10 Touch screen 12 Touch screen 15 Touch screen





HFJ-9Z2931 电脑绗缝机

Computerized quilting machine

Adopts four axis servo motor, high speed and mute. With auto lifting head and auto trimmer, use mouse to control system, with rotary hook oil storage type and automatic oil supply. Adopt precise linear guide rail, make the machine more stable and smooth.

HFJ-9Z2931 2900x3100mm
HFJ-9X2628 2600x2800mm



HFJ-8T2628 电脑绗缝机

Computerized quilting machine

Adopts four axis servo motor, high speed and mute. With auto lifting head and auto trimmer, with rotary hook oil storage type and automatic oil supply.



HFJ-8R2628 电脑绗缝机

Computerized quilting machine

Perfect design and manufacture make the quilting material more beautiful. with touch panel, when quilting, real-time dynamic tracking and pattern colorchanging display.



HFJ-5T2426 全移动电脑绗缝机

All moving computerized quilting machine

Adopts four axis servo motor, high speed and mute. With auto lifting head and auto trimmer. The area is only 3/5 size of other machine, suitable for facade room and the mall.

HFJ-5T2426 2400x2600mm
HFJ-5T2224 2200x2400mm



HFJ-5S2426 全移动电脑绗缝机

All moving computerized quilting machine

Adopts four axis servo motor, high speed and mute. The area is only 3/5 size of other machine, suitable for facade room and the mall.

HFJ-5S2426 2400x2600mm
HFJ-5S2224 2200x2400mm



HFJ-5P2426 全移动电脑绗缝机

All moving computerized quilting machine

The area is only 3/5 size of other machine, suitable for facade room and the mall. It breaks through the traditional working principle. When quilting, only the machine head need to move, without moving the quilt.

HFJ-5P2426 2400x2600mm
HFJ-5P2224 2200x2400mm

Icon	Max quilting size	Max needle drop size	Quilting thickness	S.p.m.	mm	NW/GW Kg
	HFJ-9Z2931	2900x3100mm	2700x2900mm	≈1500g/m ²	1500-2500r/min	4100x1100x1600 1780/1650
	HFJ-9X2628	2600x2800mm	2400x2600mm	≈1500g/m ²	1500-2500r/min	3800x1100x1600 1600/1500
	HFJ-8T2628	2600x2800mm	2400x2600mm	≈1200g/m ²	1500-2500r/min	3560x950x1560 1100/1200
	HFJ-8R2628	2600x2800mm	2400x2600mm	≈1200g/m ²	1500-2200r/min	3560x950x1560 1100/1200

Icon	Max quilting size	Max needle drop size	Quilting thickness	S.p.m.	mm	NW/GW Kg
	HFJ-5T2426	2400x2600mm	2200x2400mm	≈1200g/m ²	1500-2500r/min	3420x950x1150 800/720
	HFJ-5T2224	2200x2400mm	2000x2200mm	≈1200g/m ²	1500-2500r/min	3200x950x1100 800/720
	HFJ-5S2426	2400x2600mm	2200x2400mm	≈1200g/m ²	1500-2200r/min	3420x950x1150 800/720
	HFJ-5P2426	2400x2600mm	2200x2400mm	≈1200g/m ²	500-2000r/min	3150x880x1150 700/620



JK-924T 热风贴条机

Hot air seam sealing tape machine

Panasonic PLC control, up and low roller chain are synchronous, auto compensation and reverse, double pedals control blowing-in hot air is filtrated without any water and oil, it can work up to 24 hours, auto tape clipping, feeding and finishing reduce function. Suit for kinds of waterproof garment and products, such as waterproof jacket, raincoat, tent cover etc.



JK-185S-1 验布机

Fabric inspection machine, 72" width (1850mm)

With sophisticated internal infrared electronic edge controller, ensure neat cloth edge during winding. With infrared electronic automation system to control fabric loosening operation and prevents stretch material from density. Control back and forward winding movement speed to adjust fabric winging tension and re-inspect on fabric rolls miss inspection. Use high quality stepless speed controller with winding speed from 0-50m/min.

JK-185S-1 width 72" (1850mm)
JK-185S-2 width 88" (2250mm)



JK-SBJ-2L
Fabric relaxing machine



JK-235-7H 多功能小烫机

Multi functional small ironing machine

Customized PLC control system, easy to operate. Stable temperature control system, fast heating speed. Automatic lining and gluing strip feeding design, automatic unloading of upper and lower wheels synchronous transmission. Built-in automatic scissor device and pneumatic cleaning device. Suitable for ironing and gluing of welts of various fabrics.



JK-SF7-19 自动铺布机

Automatic spreading machine (width 190cm)

Adopts servo motor, which is faster, more accurate and automatically adjusts parameters. With voltage regulator, stable to use. With 40 kinds of fabric memory function. With automatic fault detection and prompt, convenient maintenance. With automatic memory cloth receiving function, improve efficiency. Suitable for needle rib woven fabrics, complex fabrics and high elastic fabrics.

JK-SF7-16 width 1600mm
JK-SF7-19 width 1900mm
JK-SF7-21 width 2100mm



JK-SF9 series
With belt type cloth bucket



JK-U60-2S-Q 超声波花边机

Ultrasonic welding machine

Seamming, trimming and embossing without glue, thread or other consumables, more faster and cost effective than traditional sewing machine and adhesive ways, eliminates fraying or unraveling of bonded edges and seams, multifunctional and thousands of designs available, requires minimum training and maintenance, super strong ultrasonic power meets the needs of different fabric thickness.



JK1707AJ 智能裁床控制系统

Automatic fabric cutting machine

This machine utilizes a self-developed cutting software system and supports customised function according to the customer's requirements. Easy operation and free upgrade for life. Standard with a single punching function, air cooling function and adsorption bed function. Optional with knife colling system.



JK-DL8 series
With continuous cutting function
(No need for second positioning when start next cutting area.)



CZD-3E 电脑伺服裁剪机
Computerized servo cutting machine

CZD-3 自动磨刀裁剪机
Auto-sharpening cutting machine

CZD-103 自动磨刀裁剪机
Auto-sharpening cutting machine



RCS-100/110/125
伺服圆刀裁剪机

Round knife cutting machine (servo motor)

With the features of free cutting, steady working, comfortable using, keen auto-sharpening. It is available to cut materials, such as cotton, woolen, linen, silk, chemical fiber, etc.

自动磨刀裁剪机

Auto-sharpening cutting machine
Blue(bright red,dark red,green,orange)

This machine is available to cut various materials, such as cotton, wool, linen, silk, chemical fiber, leather, etc. It has the features of concentrated lubrication, neat cutting section, available for curvilinear cutting, even for small curvature radius, low noise, steady running, easy to operate, high efficiency, auto-sharpening, etc.



CZD-108 5"

CZD-3

CZD-3A

CZD-3 15"

Model	Blade size	Power
CZD-3E	6",8",10",12",13",15"	1600W, 2000W
CZD-3	6",8",10",12",13",15"	550W, 750W, 850W, 1000W, 1200W
CZD-103	6",8",10",12",13",15"	550W, 750W, 850W, 1000W, 1200W

Optional:



Blue color

Black color

All black head

LED 1.2w

LED 1.5w

Arced slide knife shell

Protection cover



RSD-70

RSD-50

RSD-100

RSD-110



RSD-120

RSD-125

RSD-C1

RSD-C50



JKDB-3 全自动断布机

Full auto cloth end cutter(without table)

It is an ideal cutting machine to cut cotton, linen, silk, wind coat cloth, oilskin cloth, plastic cloth, plastic film, plastic leather, nylon, polyester, T/C, T/R, canvas, etc, the guide rail can get up and down automatically. It is the guide rail can be adjusted the pressure on the cloth, the head of the machine returns automatically, being installed with a protection device to limit cutting width, intelligent counting device, count accurately, reset automatically, etc. Being fitted with the infrared sensor, the elastic wire is without phenomena of swinging and breaking off, time-saving, effort-saving, material-saving and simple to operate, etc, cutting swiftly, grinding the blade rapidly, low noise High accuracy, pressing cut cloth neatly and tidily, synchronous belt can be cut off automatically to avoid dislocation-assist.



	Power (w)	Voltage (v)	Frequency (Hz)	Cutting width (m)	Cutting height (mm)	Rail length (M)	S.p.m.	mm	NW/GW Kg
JKDB-1	160	110/220	50/60	1.2-3.0	9	1.6-3.6	12000	760x445x200	19/22
JKDB-3	200	110/220	50/60	1.2-3.0	9	1.6-3.6	12000	760x445x200	58/63



JK-933A 全自动切布条机

Automatic cloth tape cutting machine

This product is extensive to apply kind of cylindric knit fabric cloth, cotton and polythylene fabric cloth cuts roll, slicing the cloth speed can regulate arbitrarily and establishing the auto shuts down the device, can shear fabric by 45 degree of angle, can shear the cloth's width from 15mm to 90mm.

- JK-911A Single blade
- JK-933A Double blade, speed adjustable



JK-801D 直驱切布条机

Direct drive cloth tape cutting machine

It is especially designed for cutting knitting cloth tape, the max. width of the cloth tape can be adjusted to 100mm. The specially designed cloth feeding wheel makes the operation smoothly. Single/double knife design is high efficient and easy to use.

- JK-801A Single blade
- JK-802A Double blade



JK-801A



JK-900A 带状式钢带机

Band knife cutting machine

- A: with air cushion type
- B: with frequency inverter

- JK-550A/B Table size: 1000x1200mm, cutting height: 90mm
- JK-700A/B Table size: 1200x1500mm, cutting height: 180mm
- JK-900A/B Table size: 1500x1800mm, cutting height: 180mm
- JK-1200A/B Table size: 1500x2400mm, cutting height: 250mm



JK-120LR 电脑切带机 (冷, 热刀)

Computerized cloth tape cutting machine
(cold and hot knife)

If closing the heating switch, it can cut a variety of different material such as nylon tape, cotton tape, soft plastic tube, computer cables etc. when the heating switch is open, nylon materials can be cut and edge-sealed, but except for the thick materials and cotton materials.

JK-110/120LR-Q
Cutting width 145mm

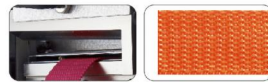

JK-120HX 电脑切带机 (热刀, 转角)

Computerized tape cutting machine
(hot knife, bevel angle)

This machine can cut bevel or straight tape, and the heat-sealing function is good at melting normally thick materials except for the cotton materials. No need change the knife and direct loosen the screw to change the knife angle to reach customer's demand.

JK-150HX
With punching function (dia 2-8mm)



JK-110HLR-300M 电脑切带机 (配送带机)

Computerized tape cutting machine with tape feeder
(cold knife, hot knife, frayed ray for label)

This machine can cut a variety of different materials such as nylon tape, cotton tape, soft plastic tube, computer cables etc. The tape feeder is mainly used for products with elasticity and tension, and plays the role of feeding the tape in advance to reduce resistance errors.



Icon	Cutting Length (mm)	Cutting Width (Max)	Cutting Speed (P/min)	Blade Temp (Max)	Voltage (V)	Frequency (Hz)	Power (Kw)	Suggested Pressure (Mpa)	mm	NW/GW Kg
	JK-120LR	10-99999	95	170	350°C	110/220	50/60	700	03-0.4	560x420x405 16/21
	JK-120LR-Q	10-99999	145	170	350°C	110/220	50/60	900	03-0.4	620x570x490 18/30
	JK-120HX	50-99999	60/98*	150	400°C	110/220	50/60	1000	03-0.4	620x540x520 30/34
	JK-150HX	30-99999	40/54	150	420°C	110/220	50/60	1050	02-0.6	820x570x780 65/78
	JK-110HLR-300M	20-9999	95	95	350°C	110/220	50/60	640		560x420x405 17/22

*Right/Bevel angle



CZ-3Z 电子钻布机

Electronic cloth drilling machine

It is one of necessary equipment used in clothing production, it has the merit of compact size, light weight and convenient operation, suit for drilling printing mark holes onto the cotton, wool, linen, silk and chemical fabric materials

CZ1-1 Cold drill
CZ1-2 Hot and cold drill
CZ-3Z Electronic drill, adjustable temperature



JK-J98 无刷双电机双头剪线机

Thread trimmer machine (double trimmer, double suction motor (brushless))

This thread cutting machine is a thread cutting equipment that integrates thread cutting and suction heads, mainly used for clothing products such as denim, knitting, and weaving. It is also suitable for sewing products such as bags, handbags, home textiles, etc.

JK-JT18 Double trimmer, single suction motor
JK-JT28 Double trimmer, double suction motor



JK-560A 吸线头机

Thread suck machine(3KW 380V)

The fierce air suction can remove the thread tip, dust, etc. It makes clothes brighter and attractive. It features visible object workable, extra-long air suction, easy operation and low noise. Suit for various fashions, shirts, western-style trousers, skirts etc.

JK-560A-1 with wheels



JKLC-1310CCD 激光切割机

Panoramic camera automatic positioning laser cutting machine(130x100cm)

Icon	Power	Laser pipe	Head Qty.	Working area	mm	NW/GW Kg
JKLC-1310CCD	60/80/100/120/130/150W	EFR,RECI,CDWG	1/2/4	1300x1000	2120x1510x850	300/350
JKLC-1810AF	60/80/100/120/130/150W	EFR,RECI,CDWG	1/2/4	1800x1000	2480x1550x1320	300/650



JKLC-1810AF 激光切割机

Automatic feeding laser engraving machine(180x100cm)



SK801A 全封闭削皮机

Totally closed leather skiving machine

Icon	Skiving width	Material thickness	mm	mm	mm
SK801A	50mm	-	1800	610x440x440	44/41
BKS-L420W	3-340mm	50mm	1400	960x360x405	110/100



JK-L20 切皮条机

Leather tape cutting machine



JK-2150PG 喷墨切割机

Ink jet cutting machine



JK-2150PR 双头喷墨绘图仪

Double head ink jet plotter

Icon	Media width Range (mm)	Valid cutting width (mm)	Print width (mm)	Software Resolution	mm	NW/GW Kg
JK-2150PG	1300-1900	1600	1850	0.025mm/step	2500x420x450	65/75
JK-2150PR	1000-2150	-	1850	0.025mm/step	2500x420x450	65/75



BKS-L420W 片皮机

Band knife splitting machine



XCLB-200 液压裁断机

Hydraulic rocker arm cutting machine

Icon	Skiving width	Split thickness	Max cutting force	Press board	Working table	Sway arm width	Cutting speed	mm	NW/GW Kg	
JK-L20	420mm	8mm	-	-	-	-	-	3.5	1800x1230x1540	890/720
XCLB-200	-	-	20T	350x500	500x1000	350x550	0.10m/s	1.5	1100x1100x1600	950/900



TP65X120A 普通烫台
Ironing Table



TD-65X120A 点动烫台
Instant-Start Vacuum Table



TDZ-80X120A 点动电加热吸风烫台
Vacuum ironing table



TDG-80X122A1 整烫一体机 (内置锅炉)
Vacuum ironing table
with built-in 4.5kw steam boiler



TDZ-Q3 条形吸风烫台
U-shape vacuum ironing table



TDZG-Q3 条形吸风烫台 (内置锅炉)
U-shape vacuum ironing table
with built-in 3kw steam boiler



JK-01A-2D 智能电加热蒸汽锅炉
Intelligent steam boiler(4kw)



JK-03A 智能语音节能电加热蒸汽锅炉
Intelligent voice speaking energy saving electric steam boiler (5kw)



DLD6-0.4-F3 节能电加热蒸汽锅炉
Energy saving electric steam boiler

DLD6-0.4-F3 6KW
DLD9-0.4-F3 9KW
DLD12-0.4-F3 12KW



DLD6-0.4-F4 全自动电加热蒸汽锅炉
Full automatic electric steam boiler

DLD6-0.4-F4 6KW
DLD9-0.4-F4 9KW
DLD12-0.4-F4 12KW



DLD6-0.4-B2 电加热蒸汽锅炉
Electric steam boiler

DLD6-0.4-B2 6KW
DLD9-0.4-B2 9KW
DLD12-0.4-B2 12KW



DLD24-0.4-A2 电加热蒸汽锅炉
Electric steam boiler

DLD18-0.4-A2 18KW
DLD24-0.4-A2 24KW

JK-AA

电脑双袖外弯蒸烫机
Computerized double sleeves elbow of suit press machine



JK-AC

电脑左大身蒸烫机
Computerized left front of suit press machine



JK-AD

电脑右大身蒸烫机
Computerized right front of suit press machine



JK-BA

电脑领袖整烫机
Computerized collar and sleeve of shirt press machine

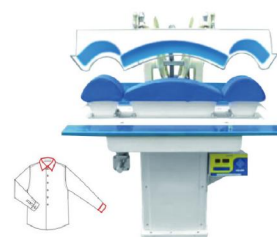

JK-BB

电脑侧缝整烫机
Computerized side seaming of shirt press machine



JK-BC

电脑门襟整烫机
Computerized placket of shirt press machine



JK-AB

电脑左右肩蒸烫机
Computerized double shoulder of suit press machine



JK-AH

电脑内外袖弯蒸烫机
Computerized inner and outer sleeve press machine



JK-AJ

电脑领圈模蒸烫机
Computerized stand collar of suit press machine



JK-BD

电脑肩背缝整烫机
Computerized back seaming of shirt press machine



JK-BE

电脑袖山整烫机
Computerized



JK-BF

电脑万能夹机
Computerized universal press machine



JK-AE

电脑侧缝蒸烫机
Computerized leg seam of suit trousers press machine



JK-AF

电脑裤腰蒸烫机
Computerized suit trousers waist press machine



JK-AG

电脑裤腿蒸烫机
Computerized suit trousers legger press machine



JK-PF101

吹裤机
Pants finishing machine



JK-PF600A

翻裤机
Vertical & horizontal pantsflipping machine



JK-FK003

电脑光板夹机
Computerized universal press machine





JK-CL101 单头烫帽机
Single-head cap ironing machine



JK-SIC01 单头烫帽机
Single-head cap ironing machine



JK-HD2020 电脑双工位烫画机
Computerized pneumatic heat transfer machine



JK-HE4060 电脑全自动双工位烫画机
Computerized pneumatic heat transfer machine



JK-CL102 自动前片机
Cap front panel pressing machine



JK-CL104 自动弯眉机
Cap curved visor blocking machine



JK4040-TD2J 气动双工位烫画机
Computerized pneumatic heat transfer machine



JK100120HP 气动双工位热升华机
Computerized pneumatic heat transfer machine



JK-CM102 双头烫帽机
Double-head cap ironing machine



JK-CL1031 烫帽一体机
Multi function cap ironing machine



JK-450MS 粘合机
Fusing machine with stand

JK-450MS Width 450mm
JK-500MS Width 500mm
JK-600MS Width 600mm



NHG900-Q1-2 直线型粘合机
Straight linear fusing machine

NHG900-Q1-2
NHG1000-Q2S
NHG1200-Q2S



JK-N630A 检针机
Needle detector



JK-AD100 双头检针机
Double head needle detector



JK-GP108D 手动包装机
Garment packing machine



JK-P207E 半自动包装机
Semi-automatic garment packing machine

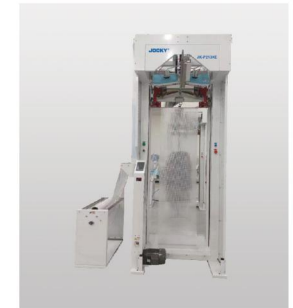

JK-P218XE 全自动包装机
Semi-automatic garment packing machine



JK-F216D 电脑打折机
Computerized fabric pleating machine



JK1893A 拉链预扩机
Zipper pre-expansion machine



JK-P307B 衬衫平面包装机
Shirt flat packaging machine



JK-FPS-1 自动折叠机
Automatic T-shirt folding machine



JK-FPS-S 衬衫自动折叠机
Automatic shirt folding machine



JK-DTF60Z-2P-BH2 白墨烫画机
DTF printer



JK-DS4-170 写真机
Digital inkjet printer



JK-FPS-FA 自动折叠包装一体机
Automatic clothes folding & packing machine



JK-TD600B 隧道整形烘干消毒机
Tunnel shaping drying and disinfecting machine



JK-20SE
电子分线机
Electronic sewing thread distributor



JK-20S
分线机
Sewing thread distributor



JK-BW5
自动分线机
Automatic bobbin thread winder



QD690S
多轴双步进平缝一体伺服控制系统
Multi-axis double step integrated servo control system
For lockstitch sewing machine



QD690
多轴单步进平缝一体伺服控制系统
Multi-axis single step integrated servo control system
For lockstitch sewing machine



QD690HSF
多轴双步进同步车一体式伺服控制系统
Multi-axis double step integrated servo control system
For lockstitch sewing machine



JK-20C
分线机
Embroidery thread distributor (2cones)



JK-40C
分线机
Embroidery thread distributor (4 cones)



JK-W118
分线机
Embroidery thread winder



QD8633/8636
直驱平缝一体式伺服控制系统
Direct drive integrated servo control system
For lockstitch sewing machine

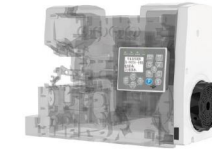

QD2632M
全自动单步进一体式伺服控制系统
Full automatic single step integrated servo control system
For overlock sewing machine



QD9632M
全自动细缝一体式单步进伺服控制系统
Full automatic single step integrated servo control system
For interlock sewing machine



JK-DM004
自动打码机
Automatic numbering machine



JK-TM826
流苏机
Soft edge tassel machine



JK-CSCK
弹力扣穿绳机
String thrusting machine for cord lock

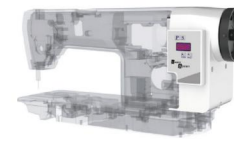

QD629A
简易一体式伺服控制系统
Direct drive servo control system
For lockstitch sewing machine

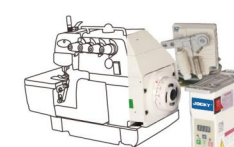

JK-O550W
Direct drive motor for overlock

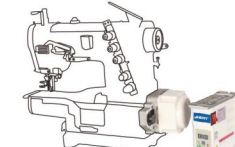

JK-I550W
Direct drive motor for interlock



JK966-10
全自动普通线绕扣机
Automatic button wrapping machine
(for normal sewing thread)



JK966-R10
全自动热熔线绕扣机
Automatic hot melting thread wrapping machine
(for hot melting thread)



JK-RK1-2
两用绕扣机
Button wrapping machine (for hot melting
thread and normal sewing thread)



JK-HL550A
节能电机
Power saving motor
JK-HL550A 550W
JK-HL750A 750W



JK-X550W
节能电机
Power saving motor
JK-X550W 550W
JK-X750W 750W



Mini motor
63# 100W
67# 150W