



JEF-T15X

Electric Counterbalance Forklift 1.5T

- Compact size and light self weight
- Small turning radius
- Large workspace
- Maintenance-free AGM battery

**ZHEJIANG JOCKY MACHINERY
TECHNOLOGY CO.,LTD**

FEATURE

■ Compact size and light self-weight

JEF-T15X features a compact size and offers great maneuverability to cope with handling tasks in narrow spaces. With this 2200kg light-weight truck, operators can drive smoothly for cargo lift and mezzanine operation.



■ Small turning radius

JEF-T15X comes with small turning radius of 1495mm, which makes it a flexible tool for the electronics, textile and lighting industries.



■ Large workspace

Thanks to ergonomic improvements, JEF-T15X provides a large legroom for comfortable operation and improved work efficiency.



■ Maintenance-free AGM battery

JEF-T15X adopts 48V/180Ah maintenance-free AGM battery, which effectively reduces operation costs.



Electric Counterbalance Forklift 1.5T

JEF-T15X

Distinguishing mark	1.1	Manufacturer			JUKILIFT
	1.2	Model designation			JEF-T15X
	1.3	Drive			Electric
	1.4	Operator type			Seated
	1.5	Load capacity	Q	kg	1500
	1.6	Load center distance	c	mm	500
	1.8	Load distance , centre of drive axle to fork	x	mm	265
	1.9	Wheelbase	y	mm	1275
	Service weight	2.1	Service weight		kg
2.2		Axle loading, laden front/rear		kg	3290/410
2.3		Axle loading, unladen front/rear		kg	890/1310
Tyres/chassis	3.1	Tyre type			Solid Rubber
	3.2	Tyre size, front			330×145
	3.3	Tyre size, rear			330×145
	3.5	Wheels, number front/rear (x=drive wheels)		mm	2/1x
	3.6	Tread width, front	b10	mm	905
	3.7	Tread width, rear	b11	mm	—
	Dimensions	4.1	Tilt of mast/fork carriage forward/backward	α/β	°
4.2		Retracted mast height	h1	mm	1980
4.3		Free lift	h2	mm	100
4.4		Lift height	h3	mm	3000
4.5		Height, mast extended	h4	mm	4054
4.7		Height of overhead guard (cabin)	h6	mm	1995
4.8		Seat height/standing height	h7	mm	985
4.12		Tow coupling height	h10	mm	660
4.19		Overall length	l1	mm	2680
4.20		Length to face of forks	l2	mm	1760
4.21		Overall width	b1/b2	mm	1060
4.22		Fork dimensions	s/e/l	mm	40×100×920
4.23		A,B Fork carriage class/type A, B			2A
4.24		Fork carriage width	b3	mm	1040
4.31		Ground clearance, laden, below mast	m1	mm	90
4.32		Ground clearance, center of wheelbase	m2	mm	78
4.34.1		Aisle width for pallets 1000×1200 crossways	Ast	mm	3095
4.34.2		Aisle width for pallets 800×1200 crossways	Ast	mm	3213
4.35		Turning radius	Wa	mm	1495
Performance data	5.1	Travel speed, laden/unladen		km/h	8/9
	5.2	Lifting speed, laden/unladen		m/s	0.25/0.3
	5.3	Lowering speed, laden/unladen		m/s	0.44/0.425
	5.5	Drawbar pull, laden/unladen		N	—
	5.6	Max. drawbar pull, laden/unladen		N	—
	5.8	Max. gradeability, laden/unladen		%	10/12
	5.10	Service brake			Hydraulic
5.11	Parking brake			Mechanical	
Electric-engine	6.1	Drive motor rating S2 60 min		kW	4.5
	6.2	Lift motor rating at S3 15%		kW	5
	6.4	Battery voltage/nominal capacity		V/Ah	48V/180Ah
	6.5	Battery weight		kg	—
Addition data	8.1	Type of drive control			AC
	10.5	Steering design			Hydraulic
	10.7	Sound pressure level at the driver's ear		dB(A)	< 70

If there are improvements of technical parameters or configurations, no further notice will be given.
The diagram shown may contain non-standard configurations.

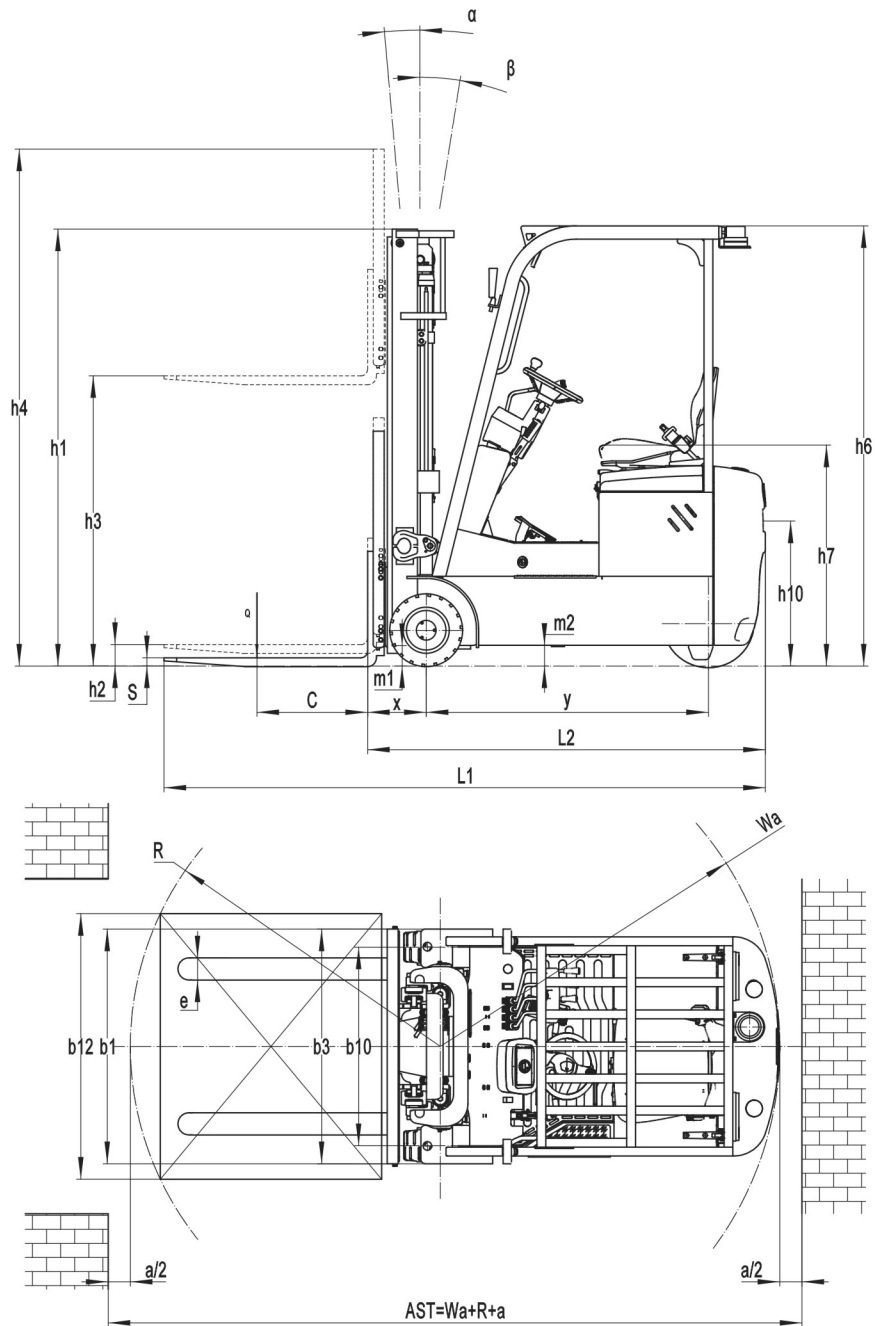

RATED CAPACITIES AND LOAD CENTERES GRAPH

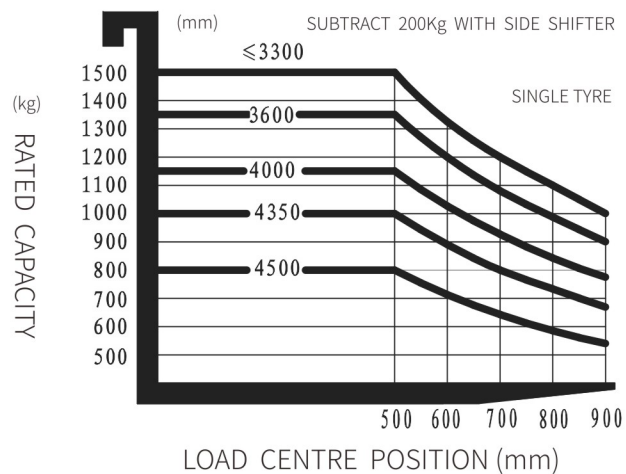

Mast Option

Mast types	Lift height (h3)	Height, Mast			Height, Free lift(h2)	
		Height, mast lowered(h1)	Height, mast extended(h4)		No backrest	With backrest
	mm		mm	mm		
2-Standard Mast	2500	1730	3046	3554	100	100
	2700	1830	3246	3754	100	100
	3000	1980	3546	4054	100	100
	3300	2130	3846	4354	100	100
	3600	2280	4146	4654	100	100
2-Free Mast	3000	2010	3546	4054	1494	986
	3300	2160	3846	4354	1644	1136
	3600	2310	4146	4654	1794	1286
3-Free Mast	4000	1830	4546	5054	1314	806
	4350	1980	4896	5404	1464	956
	4500	2030	5046	5554	1514	1006

Option

No.	Optional items	JEF-T15X
1.1	Fork dimension	●100*40*920○100*40*1070○100*40*1100 ○100*40*1150○100*40*1220○100*40*1370○100*40*1520
1.4	Fork carriage width	●1040mm○Yes and can be customized
1.5	Fork carriage height	●1025mm○Yes and can be customized
2.5	Front wheel material	●solid
2.6	Rear wheel material	●solid
2.7	Battery capacity	●48V180AH (AGM)○48V150AH (Li-ion)
2.8	Charger	●48V30A(External) ○48V30A-Li Internal○48V50A-Li Internal
2.10	Seat type	●Regular○Premium
2.11	Attachments	●No○Built-in sideshifter○External shifter○Adjustable fork
2.13	Traction pin	●Yes
3.5	Front lamp	●LED
3.6	Rear lamp	●NO○LED
3.7	Warning lamp	●Yes
3.8	Steering lamp	●Yes
3.9	Blue lamp	●NO○2 front○1 rear○2 front + 1 rear
3.10	Area warning lamp	●NO○1 left + 1 right (Red)
3.11	Rearview mirror	●One Rearview mirror○Two Rearview mirror
3.12	Buzzer	●Yes
3.15	Fire extinguisher	●NO○Yes and not customized
3.17	OPS system	●NO○Yes and not customized
3.23	Telematics	●NO○Yes and not customized

Note : ●Standard ○ Op tional - Inconformity